



**ANODYNE
ELECTRONICS
MANUFACTURING CORP.**

SPECIAL NOTICE

This product is now licensed to Anodyne Electronics Manufacturing (AEM) from Northern Airborne Technology (NAT). AEM is responsible for all matters related to this product, including sales, support and repair services.

Please note the transition to convert product manuals and supporting documentation is an ongoing process and is being addressed on an 'as needed' basis.

All references to NAT product part numbers (and associated images) are equivalent to AEM product part numbers.

Contact info:

Anodyne Electronics Manufacturing Corp.

#15-1925 Kirschner Road

Kelowna B.C. Canada

V1Y 4N7

Email: support@aem-corp.com

Toll Free: **1-888-763-1088**

Phone: 1-250-763-1088

Fax: 1-250-763-1089

www.aem-corp.com

#15-1925 Kirschner Road, Kelowna BC Canada, V1Y 4N7

toll free 1-888-763-1088 t 250-763-1088 f 250-763-1089

www.aem-corp.com



SM44-1

**PA250 Series
High Power Voice Amplifier**



INSTALLATION AND OPERATION MANUAL

Rev: 2.00 April 22, 2012

**Anodyne Electronics Manufacturing Corp.
15-1925 Kirschner Road
Kelowna, BC, Canada.
V1Y 4N7**

**Telephone (250) 763-1088
Facsimile (250) 763-1089**

Website: www.aem-corp.com

**© 2012 Anodyne Electronics Manufacturing Corp. (AEM),
All Rights Reserved**



PA250 Series High Power Voice Amplifier SM44-1 Installation and Operation Manual







COPYRIGHT STATEMENT

© 2012 Anodyne Electronics Manufacturing Corp. (AEM), All Rights Reserved

This publication is the property of AEM and is protected by Canadian copyright laws. No part of this document may be reproduced or transmitted in any form or by any means including electronic, mechanical, photocopying, recording, or otherwise, without the prior written permission of AEM.



**PA250 Series High Power Voice Amplifier
SM44-1 Installation and Operation Manual**

Prepared By:  Tony Pearson Designer Apr 22, 2012 	Checked By:  Loen Clement Designer May 24/12 	Approved By:  Tom Betzelt Product Support Manager May 28, 2012 
---	---	--

The status of this installation and operation manual is controlled by issue shown on the title page. The status of each section is controlled by revision shown in the footer of each page. All revisions affecting sections of this manual have been incorporated into the latest issue.

ISSUE/REVISION RECORD			
Manual Issue Number	Section Revision Number	Revision Description	Issue Date
4.02	Section 2 Rev: 1.01	Updated with the latest drawings.	Mar 10, 2009
4.01	Section 1 Rev: 1.00 Section 2 Rev: 1.00 Section 3 Rev: 1.00	Update to current templates. Updated Section 2 with the latest drawings.	Aug 13, 2008
AEM MANUAL REVISIONS			
Section	Revision Number	Revision Description	Date
All	Rev 2.00	Updated drawings and template	April 22, 2012



PA250 Series High Power Voice Amplifier SM44-1 Installation and Operation Manual

Table of Contents

Section	Title	Page
1.0	Description	
1.1	Introduction	1-1
1.2	Product Description	1-1
1.3	Design Features	1-1
1.4	Specifications	1-2
1.4.1	Electrical Specifications	1-2
1.4.2	Physical Specifications	1-2
1.4.3	Environmental Specifications	1-3
1.5	Auxiliary Components	1-3
1.5.1	Control Panel	1-3
1.5.2	Microphone	1-3
1.5.3	Loudspeakers	1-4
1.5.4	Power Supplies	1-5
2.0	Installation	
2.1	Introduction	2-1
2.2	Unpacking and Inspection	2-1
2.2.1	Warranty	2-1
2.3	Continued Airworthiness	2-1
2.4	Installation Procedures	2-2
2.4.1	Cautions	2-2
2.4.2	Cabling and Wiring	2-2
2.4.3	Ground Site Selection	2-3
2.4.4	Aiborne Installation	2-3
2.4.5	Remote Installation	2-3
2.4.6	Post Installation Checks	2-4
2.5	Accessories	2-5
2.5.1	Dummy Load	2-5
2.5.2	Meter Test Set	2-5
2.5.3	Protective Circuit Test Unit	2-5
2.5.4	Paralleling Transformers	2-5
2.5.5	Remote Controls	2-5
2.5.6	Tape Recorders/Players	2-5
2.6	Accessories Required But Not Supplied	2-6
2.6.1	Power/Speaker Kit	2-6
2.6.2	Recorder Input Kit	2-6
2.6.3	Microphone Input Kit	2-6
2.6.4	Remote Input Kit	2-7
2.7	Installation Drawings	2-7



PA250 Series High Power Voice Amplifier SM44-1 Installation and Operation Manual

Section	Title	Page
3.0	Operation	
3.1	Introduction	3-1
3.2	General Information	3-1
3.3	Controls and Indicators	3-1
3.3.1	POWER Switch	3-1
3.3.2	POWER Lamp	3-2
3.3.3	GAIN Control	3-2
3.3.4	AUDIO POWER (Level) Meter	3-3
3.3.5	OVERLOAD Indicator LED	3-3
3.3.6	Resetting the Protective Circuit	3-3



PA250 Series High Power Voice Amplifier SM44-1 Installation and Operation Manual

Section 1.0 Description

1.1 Introduction

Information in this section consists of product description, design features and specifications for the PA250 Series High Power Voice Amplifier. All derivative product information shall be contained in the applicable manual supplement, which may be obtained from AEM as required.

Review all notes, warning and cautions.

1.2 Product Description

The completely transistorized PA250 Series provides the basis for a portable, high gain tactical sound system. It is designed to provide point-to-point dissemination of sound in application use over land, water or from the air. The maximum useable range is greater than one mile when operated from a favourable vantage point. The nominal rated audio power output is 250 watts with 28 Vdc input power.

Note: In airborne applications, the amplifier is normally remote-mounted in the avionics bay and the PA250 Series controls are not operator accessible. Any necessary adjustments must be made at the time of installation.

1.3 Design Features

The PA250 Series amplifier is a 250 watt completely transistorized unit constructed in a rugged, black anodized, aluminum chassis. Its reliability is enhanced by conservative design and a unique built-in protective circuit, which shuts off the amplifier whenever excessive input or operating conditions threaten to impair vital circuit elements.

The PA250 Series contains protective circuits, which operate to protect the semiconductor components from the following conditions:

- a) Reverse polarity
- b) Excessive current or voltage
- c) Internal or external short circuits

When the problem is transient or cleared, the protective circuit resets by the simple operation of the power switch.



PA250 Series High Power Voice Amplifier SM44-1 Installation and Operation Manual

1.4 Specifications

1.4.1 Electrical Specifications

Input Power

Supply Voltage	+24 to +36 Vdc normal +28 Vdc max.
Supply Impedance	<0.05 Ω
Supply Current	0.01 A @ +28 Vdc (no signal) 15-20 A @ +28 Vdc (full power out) 3 A @ +28 Vdc (voice operation)

Input Signals

The signal levels shown below are required for full amplifier drive at the points and impedances shown.

JACK	PINS	IMPEDANCE	INPUT LEVEL
MIC	A-C	150 Ω	0.005 Vrms
REC	B-C	600 Ω	0.5 Vrms
REC	A-C	2000 Ω	1.0 Vrms

Output Signals

Output Power	250 watts into 1.75 Ω , with a 5 mVrms, 1 kHz signal applied to the microphone input
Output Load Impedance	1.4 to 1.75 Ω each channel. (Nominal 2 Ω) Amplifier shut-down if load <1 Ω
Frequency Response	<3 dB over 500 to 5000 Hz
Harmonic Distortion	\leq 10% at 40% rated power, with 1000 Hz sine wave input

1.4.2 Physical Specifications

Height	4.26" (108.3 mm) including controls
Depth	10.00" (254.0 mm) including mounting plate 9.17" (232.8 mm) excluding mounting plate
Width	8.75" (222.3 mm) including mounting plate 6.63" (168.4 mm) excluding mounting plate
Weight	6.75 lbs (3.06 kg)



PA250 Series High Power Voice Amplifier SM44-1 Installation and Operation Manual

1.4.3 Environmental Specifications

Temperature	-35 to +60°C
Altitude	25,000 feet

1.5 Auxiliary Components

The PA250 Series amplifier is designed to operate with specific compatible components to form an effective sound system.

1.5.1 Control Panel

1.5.1.1 AA21

The AA21 Cabin PA control unit is designed to provide centralized control for an aircraft's internal and external PA systems. The unit is Dzus mounted with an illuminated faceplate and a front panel switch to provide selection of the various operational modes. The AA21 provides two low level audio signal outputs that drive the input on remote mounted power amplifiers. One output is designed to drive the PA110/220 series amplifiers and the other output is designed to drive the PA250/700 series amplifiers.

1.5.1.2 AA22

The AA22 PA/Siren control unit is a compact, self contained, Dzus mounted unit for use with the PA250 and PA700 series audio power amplifiers. It has a low level output rated at 500 mVrms. It provides a centralized control for external audio paging and siren functions.

1.5.1.3 PM01-001

The PM01-001 is a remote control device designed as the operating station for a high power audio system. The PM01-001 is equipped with two decibel meters which make it ideal for monitoring either one or two power amplifiers.

1.5.2 Microphone

1.5.2.1 PM03-002

The PM03-002 is a hand-held, dynamic and noise-cancelling microphone with a push-to-talk button. It comes with a coiled retractable cable and connector for direct connection to the amplifier or remote control unit such as the PM01-001.



PA250 Series High Power Voice Amplifier SM44-1 Installation and Operation Manual

1.5.3 Loudspeakers

Various types of loudspeaker arrays can be used in sound systems using the PA250/700 amplifiers. They are identified by the style and number of drivers (and bells) in each speaker array as shown in Table 1. As a guideline for system configuration, there should be a minimum of 1 speaker driver/bell assembly for each 100 watts of amplifier power.

Part No.	Description
TS92-02XN	Standard two-bell array with drivers
TS92-04XN	Standard four-bell array with drivers
TS93-04XN	Standard four-bell cloverleaf array with drivers
TS94-04XN	Standard four-bell mini speaker array with drivers

Table 1
Speaker Arrays

For comparison, the efficiencies of the four-bell speakers are shown in Table 2 (assuming the same input power is delivered to each type).

Part No.	Description	Efficiency
TS92-02XN	Standard two-bell array with drivers	100%
TS92-04XN	Standard four-bell array with drivers	195%

Table 2
Efficiencies

The higher efficiency rating is due to more concentrated sound patterns and lower, more efficient power conversion at each speaker driver. The larger speakers can also accept more power from the amplifying system and may show an even better efficiency rating than these figures indicate.

1.5.3.1 TS92-02XN

The two-bell speaker array is widely used in airborne applications where its light weight and small size are important considerations. While its output efficiency is not equal to that of the larger loudspeaker types, it performs well on small and medium-sized aircraft. The size and weight of the two-bell speaker often permits it to become a permanent installation in the aircraft.

1.5.3.2 TS92-04XN

The four-bell loudspeaker is almost universally chosen for portable sound systems. The greater efficiency compensates for the additional weight compared to the two-bell speaker.

1.5.3.3 Multiple Speakers

The TS9X is designed to be assembled in groups of two, four or more. This permits the use of multiple amplifying systems for higher sound levels and greater distance.



PA250 Series High Power Voice Amplifier SM44-1 Installation and Operation Manual

1.5.4 Power Supplies

Power can be supplied by storage batteries, electronic supplies or vehicle/aircraft power systems. Vehicle supplies of 24 – 28 Vdc are an obvious choice for most airborne/mobile installations. The 12 – 14 Vdc supply of the commercial vehicle can not be used.

In the hand-pack series, sealed nickel cadmium cells are used. Adding extra cells can almost double the available power.

Electronic power supplies are frequently used in maintenance shops and fixed installations. A minimum requirement would be a well regulated supply of 20 - 40 Vdc at 25 A.

1.5.4.1 VR33-001 Power Converter

The VR33-001 is a power conversion device designed to increase the nominal 28 Vdc aircraft voltage to 33 Vdc using high speed switching DC-DC conversion. The VR33-002 is designed to be used with the PA250 Series Audio Power Amplifier.

End of Section 1.0



PA250 Series High Power Voice Amplifier SM44-1 Installation and Operation Manual

Section 2.0 Installation

2.1 Introduction

Information in this section consists of unpacking and inspection procedures, installation procedures, post-installation checks and installation drawings for the PA250 Series High Power Voice Amplifier.

Review all notes, warnings and cautions.

2.2 Unpacking and Inspection

Unpack the equipment carefully. Inspect the unit visually for damage due to shipping and report all such claims immediately to the carrier involved. Check that all items listed below are present before proceeding and report any shortage immediately to your supplier:

- PA250 Series High Power Voice Amplifier
- Product Information Card
- Certificate of Conformity or Release Certification

2.2.1 Warranty

All Anodyne Electronics Manufacturing Corp. (AEM) products are warranted for 2 years. See the website www.aem-corp.com/warranty for complete details.

2.3 Continued Airworthiness

Maintenance of the PA250 Series High Power Voice Amplifier is 'on condition' only. Periodic maintenance of this product is not required.



PA250 Series High Power Voice Amplifier SM44-1 Installation and Operation Manual

2.4 Installation Procedures

2.4.1 Cautions

CAUTION:

Use of a fully floating audio wattmeter or transformer coupled meter is recommended. Always check ADF and compass calibration after installing external speakers or 'PA' amplifiers. Significant single cycle errors may be caused by the concentration of steel and magnetic material.

Use shielded cable exactly as shown and ground as indicated. All audio installations can be severely degraded by incorrect wiring and shielding. Unusual buzzes, hums or other background audio are symptomatic of multiple grounds, or noisy external systems such as blowers or pumps sharing wiring with the audio system. Never operate this unit below its rated impedance.

When a remote control unit is used, all signal inputs must be made at that unit and a cable of appropriate length will be necessary to connect it to the amplifier.

Precautions are necessary when external signals, such as intercom, radio or recorders are used. The high gain of the amplifier requires care to prevent feedback or crosstalk. Ground loops and stray currents in the input line must be eliminated.

2.4.2 Cabling and Wiring

All wire shall be selected in accordance with the original aircraft manufacturer's Maintenance Instructions or AC43.13-1B Change 1, Paragraphs 11-76 through 11-78. Unshielded wire types shall qualify to MIL-W-22759 as specified in AC43.13-1B Change 1, Paragraphs 11-85, 11-86, and listed in Table 11-11. For shielded wire applications, use Tefzel MIL-C-27500 shielded wire with solder sleeves (for shield terminations) to make the most compact and easily terminated interconnect. Follow the connector map in Section 2.7 as required.

Allow 3" from the end of the shielded wiring to the shield termination to allow the connector hood to be easily installed. Reference the interconnect drawing in Section 2.7 for shield termination details.

Maintain wire segregation and route wiring in accordance with the original aircraft manufacturers Maintenance Instructions.

Unless otherwise noted, all wiring shall be a minimum of 22 AWG, except power and ground lines, which shall be a minimum of 20 AWG. Reference the Interconnect drawing for additional specifications. Check that the ground connection is clean and well secured, and that it shares no path with any electrically noisy aircraft accessories such as blowers, turn and bank instruments or similar loads. Power to this unit must be supplied from a separate circuit breaker or fuse (fast blow), and not attached to any other circuit breaker without additional protection. Verify that the selected circuit breaker size and wire gauge are adequate for the installation using the techniques specified in AC43.13-1B Change 1, Paragraphs 11-47 through 11-51 and 11-66 through 11-69.



PA250 Series High Power Voice Amplifier SM44-1 Installation and Operation Manual

2.4.3 Ground Site Selection

Sound waves transmitted through air are strongly affected by wind, weather, time of day and intervening objects. Satisfactory sound projection over great distances is possible from a well-situated operating site that can take maximum advantage of these natural elements.

Optimum location of the loudspeakers is the prime controlling factor in site selection. This is especially important when maximum projection is required.

An operating location with a line-of-sight observation of the target objective is desirable. For example, a hillside location with the loudspeakers directed down or across the valley would be ideal. Sound carries well across water and consequently advantage can be taken of a river or a lake to improve sound transmission. It is preferable to locate upwind of the target in order to benefit from the carrying power of the wind. Whenever possible, the site should be free of foliage or other obstructions for several hundred yards in front of the loudspeakers.

Directional sound bends away from warm surfaces. For example, transmissions over warm pavements attenuate rapidly with distance, as the sound 'curls upward' into the cooler upper air.

2.4.4 Airborne Installation

Experience shows that sound projection from fixed wing or rotor aircraft is possible up to 2 miles slant range. If a circling course is planned, the loudspeakers should point horizontally alongside or at right angles to the airframe. This permits the bank of the aircraft or the downward thrust of rotor blades to direct the sound beam toward the ground target. To reduce air resistance, the speakers may be mounted in an open doorway or fitted into a streamlined pod. From a hovering helicopter, intelligibility is improved by focusing the directional sound to an area outside the rotor blast.

When an input audio line from an intercom, radio, recorder, etc. to REC input is used, precautions are necessary. The high gain of the amplifier requires care in prevention of feedback. Complete elimination of ground loop and stray currents in the input line is mandatory. This may mean an isolation transformer is necessary, if not otherwise provided by the signal source. Refer to Dwg No. AA22\492\403-1 for details of an aviation-specific interconnect.

Shielding the microphone from direct sound waves from the speakers prevents acoustic feedback. This may be achieved using an enclosure, or by operating at a considerable distance behind the speaker pattern.

Multiple speakers require correct phasing, otherwise sound cancellation will greatly reduce the projected power. The proper phasing is provided by the cables supplied. If any repairs or re-cabling are required, the wiring should be checked from Dwg No. PA250\407-0.

2.4.5 Remote Installation

For installations where the Audio Power Amplifier will be remote mounted, it is recommended that the knob be removed from the GAIN control and be replaced with the compression fitting (AEM Part No. 25-01-002, Smith p/n 181) supplied in the PAREC-IKS and PAMIC-IKS install kits. Do not remove the nut that secures the GAIN potentiometer to the control panel. Once the compression fitting is installed on the bushing of the potentiometer, set the GAIN control to the desired setting then carefully tighten the compression fitting on to the shaft of the GAIN control potentiometer.



PA250 Series High Power Voice Amplifier SM44-1 Installation and Operation Manual

2.4.6 Post Installation Checks

The PA system is not intended to be operated in a linear volume manner (i.e., it is not like a stereo system). The PA is designed to provide high levels of audio power under difficult conditions and does so by sacrificing some of the high fidelity for a higher average power output. The volume control on the AA21/AA22 is not intended to provide linear operations from the PA system and will result in broken and sporadic output from the PA when insufficient levels are delivered to the AA21/AA22 and/or to the PA250 unit from the AA21/AA22.

For most RADIO and PA (voice) operations, it is suggested that the AA21/AA22 volume control be set to maximum (fully cw). If the system is overdriving, reduce the AA21/AA22 volume setting.

To check the system, the aircraft must be moved outside and away from as many reflective surfaces as possible. It is not recommended to operate the PA microphone on the ground, as a high risk exists for audio coupling and feedback. However, if the test is to be conducted on the ground, the aircraft should be positioned on a grassy surface to help reduce the distortion produced by sound reflected from concrete or asphalt. It is also beneficial to stuff the speaker projectors with soft rubberized foam to reduce the risk of feedback and distortion.

Note: Advise all nearby personnel that PA system tests are to be conducted.

Start by checking the Siren Circuit for proper operation and tone/rate adjustment. The Siren always operates at 100% output from the AA21/AA22 and should drive the PA's to full output on audio peaks. The Level trimpot(s) of the AA21/AA22 will be set at the factory to provide rated output at full front panel volume control adjustment.

Once the siren operation is satisfactory, you may try RADIO operations through the AA21/AA22. To achieve full output capability from the AA21/AA22, a signal of 2.5 Vrms at 1 kHz must be delivered to the AA21/AA22 radio audio input and the AA21/AA22 volume must be set to maximum. Lower levels of input signal or volume settings will result in poor output audio (very broken).

For PA (voice) tests, it is best that the aircraft is flown in an approximately 200 foot hover and commands are given to a human ground target for visual response to the commands. Remember, the human target should be positioned in the area that the speaker system is designed to project the audio to. This will depend on speaker orientation and the height "above ground level" (AGL) of the aircraft. To achieve the best operation, all voice commands must be spoken slowly and clearly, with extra emphasis on each word.

Note: Remove all sound absorbing material from the speakers prior to flight.

To determine the operational capability of the system, put the aircraft in a hover and with the target properly positioned, provide PA instruction to the target to accomplish a certain task that will give visual cue to the flight crew that the target has understood the instructions (i.e., "touch your head", "sit down", "turn around", etc.).

Upon satisfactory completion of all performance checks, make all required log book entries, electrical load, weight and balance amendments and other documentation as required by your local regulatory agency before releasing the aircraft for service.



PA250 Series High Power Voice Amplifier SM44-1 Installation and Operation Manual

2.5 Accessories

A range of accessories are available for testing and complementing the sound system.

2.5.1 Dummy Load

The TL-PA2 is a 2 ohm resistive load with a three foot cable and type MS3106A-16-11P connector for ready substitution in the speaker circuit or for connecting to the Meter Test Unit. One dummy load should be used per channel. The use of resistive dummy load facilitates testing and power measurements, especially when 'quiet' operation is desirable.

2.5.2 Meter Test Set

The TL-PA4 Meter Test Set is a convenient test unit complete with connectors and cables for inserting into the power circuits of an amplifier and measuring both the DC current drawn and AC voltage generated across the load. The load may be either the speakers or the TL-PA2 dummy load (checks one channel at a time).

2.5.3 Protective Circuit Test Unit

A Protective Circuit Test Unit is available to test the protective circuit so that its proper adjustment is assured. This unit, used with the TL-PA2 dummy load, provides GO/NO GO limits for correctly setting the trip level.

2.5.4 Paralleling Transformers

Paralleling transformers are available for driving up to four amplifiers from the same audio signal source.

2.5.5 Remote Controls

Units may be obtained to control and/or monitor between one and eight amplifiers in parallel. All remote units provide audio gain control and on-off power switching. A special junction box located at the amplifiers is required in multiple amplifier systems for cable terminations and control functions. Aviation specific configurations and other information are available upon request.

If the installation is configured using a PM01 type remote control, the POWER switch on the PA250 should be set to 'OFF/REMOTE'. If the installation uses an AA21/AA22 type remote control, the POWER switch should be set to 'ON'.

2.5.6 Tape Recorder/Players

Cables and adapters are available to interface tape recorders with the high powered voice amplifier systems.



PA250 Series High Power Voice Amplifier SM44-1 Installation and Operation Manual

2.6 Accessories Required But Not Supplied

Installation kits are required to complete the installation. They consist of the following:

2.6.1 Power/Speaker Kit

This kit is used for the Power/Speaker connection. For a straight connection use PAPWR-IKS and for a right angle connection use PAPWR-IKSR.

PAPWR-IKS consists of

Quantity	Description	AEM Part No.
1	MS 5 Pin Female Straight Sealed Solder Cup	20-42-001

PAPWR-IKSR consists of

Quantity	Description	AEM Part No.
1	MS 5 Pin Female 90° Sealed Solder Cup	20-39-005

2.6.2 Recorder Input Kit

This kit is used for the Recorder input connection. For a straight connection use PAREC-IKS and for a right angle connection use PAREC-IKSR.

PAREC-IKS consists of

Quantity	Description	AEM Part No.
1	MS 3 Pin Female Straight Sealed Solder Cup	20-42-003
1	Nut, Shaft Locking ¼"	25-01-002

PAREC-IKSR consists of

Quantity	Description	AEM Part No.
1	MS 3 Pin Female 90° Sealed Solder Cup	20-39-003
1	Nut, Shaft Locking ¼"	25-01-002

2.6.3 Microphone Input Kit

This kit is used for the Microphone input connection. For a straight connection use PAMIC-IKS and for a right angle connection use PAMIC-IKSR.

PAMIC-IKS consists of

Quantity	Description	AEM Part No.
1	MS 3 Pin Female Straight Sealed Solder Cup	20-42-003
1	Nut, Shaft Locking ¼"	25-01-002



PA250 Series High Power Voice Amplifier SM44-1 Installation and Operation Manual

PAMIC-IKSR consists of

Quantity	Description	AEM Part No.
1	MS 3 Pin Female 90° Sealed Solder Cup	20-39-003
1	Nut, Shaft Locking ¼"	25-01-002

2.6.4 Remote Input Kit

This kit is used for the Remote input connection. For a straight connection use PAREM-IKS and for a right angle connection use PAREM-IKSR.

PAREM-IKS consists of

Quantity	Description	AEM Part No.
1	MS 7 Pin Female Straight Sealed Solder Cup	20-42-007

PAREM-IKSR consists of

Quantity	Description	AEM Part No.
1	MS 7 Pin Female 90° Sealed Solder Cup	20-39-007

2.7 Installation Drawings

DOCUMENT	REV.	DESCRIPTION	TYPE	SERIAL NO.
AA21-400				
AA21\400\403-0	1.01	Cabin PA System	Interconnect	All
AA22-492				
AA22\492\403-0	1.10	PA/Siren System	Interconnect	All
AA22\492\403-1	1.10	PA/Siren System	Interconnect	All
AA22\492\403-2	1.10	PA/Siren System	Interconnect	All
PA250				
PA250\407-0	1.00	PA250 Amplifier	Cabling Diagram	All
PA250-001				
PA250\001\407-0	1.00	250 Watt System	Cabling Diagram	All
PA250\001\922-0	2.10	Audio Power Amplifier	Mechanical Installation	All

Section 2.0 ends following the above documents

REVISIONS			
REV	DESCRIPTION	DATE	BY
1.01	DOCCRO2739 - ADDED NOTE 8.	FEB 5/09	TAT

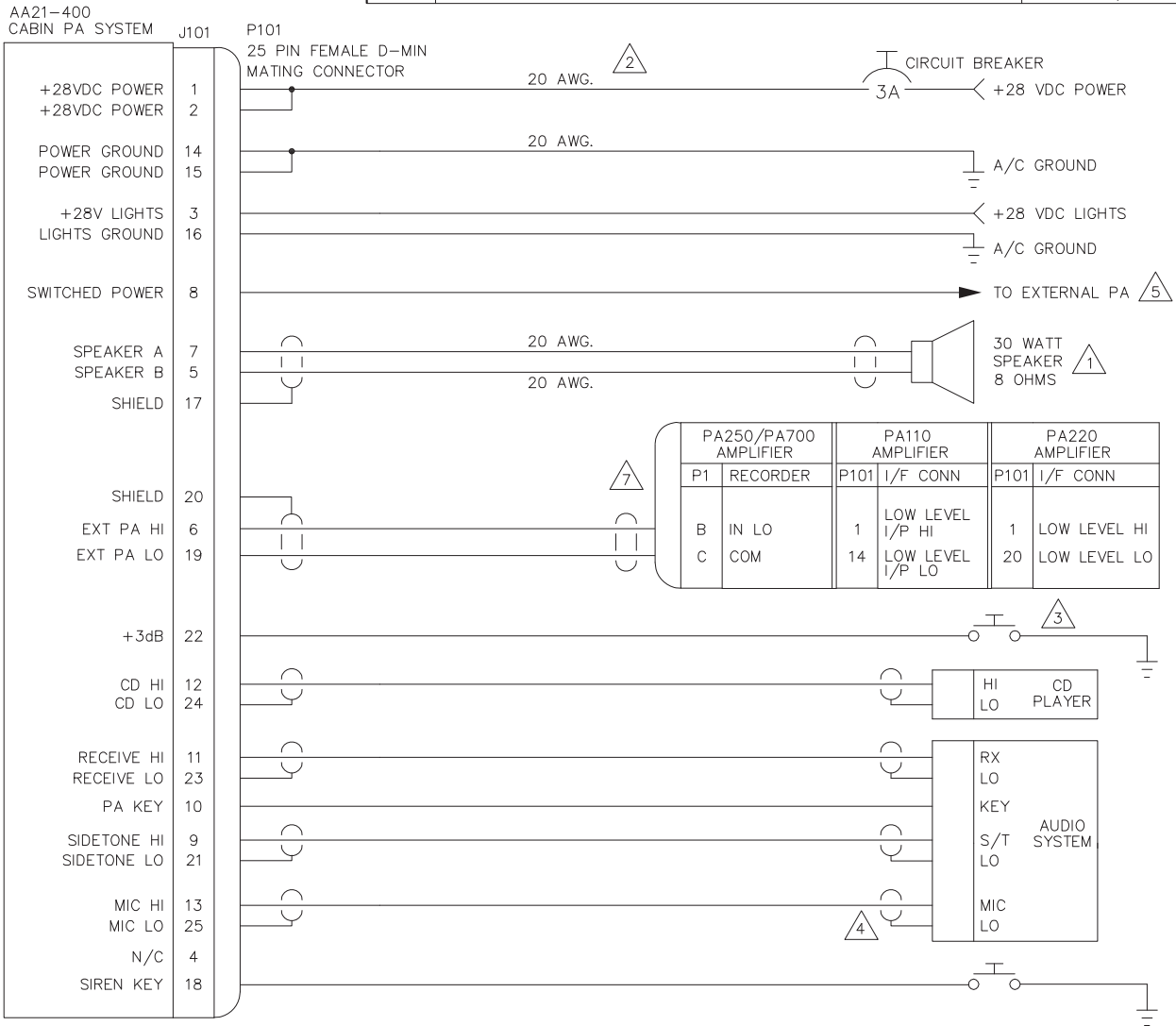

NOTES:

- 1 EQUIVALENT SERIES/PARALLEL SPEAKERS MAY BE USED.
- 2 ALL WIRES SHOULD BE 22 AWG UNLESS OTHERWISE SPECIFIED. ALL UNSHIELDED WIRE SHALL BE SELECTED IN ACCORDANCE WITH AC43.13-1B CHANGE 1, PARAGRAPHS 11-76 THROUGH 11-78. WIRE TYPES SHOULD BE TO MIL-W-22759 AS SPECIFIED IN AC43.13-1B CHANGE 1, PARAGRAPHS 11-85, 11-86 AND LISTED IN TABLE 11-11. ALL SHIELDED WIRE/CABLE SHOULD BE IN ACCORDANCE WITH MIL-C-27500.
- 3 GROUND TO REDUCE OUTPUT BY 3dB.
- 4 MIC LO MUST BE GROUNDED AT AUDIO PANEL.
- 5 +28VDC @ 400mA MAX.
- 6 JUMPER CONFIGURED. ONLY RECEIVE OR CD MAY BE USED AT ONE TIME.
- 7 REFER TO AA21 INSTALLATION AND OPERATION MANUAL FOR CORRESPONDING AA21 JUMPER SETTING.
- 8 WHEN CONNECTED TO AN AUDIO SYSTEM WITHOUT A PA KEY OUTPUT, CONNECT PIN 10 TO GROUND. WHEN CONNECTED TO AN AUDIO SYSTEM WITH A PA KEY OUTPUT, CONNECT AS SHOWN

PROPRIETARY AND CONFIDENTIAL TO NAT LTD.

DEFINITIONS:

N/C:
NO CONNECTION. THE PIN IS NOT CONNECTED TO ANYTHING INTERNALLY, AND THEREFORE SHALL HAVE NO CONNECTION EXTERNALLY.

RESERVED:
MAY BE CONNECTED AND USED IN THE FUTURE. THE CIRCUITRY MAY BE PRESENT OR ADDED TO ACTIVATE THE FUNCTION. THE PIN MAY BE USED FOR TEST PURPOSES. THERE IS NO EXTERNAL CONNECTION.

DESIGNED	RL	NAT NORTHERN AIRBORNE TECHNOLOGY LTD.				
DRAWN	SRK					
DATE	NOV 9/99	TITLE				CABIN PA SYSTEM
CHECKED	NAT 255	SIZE				A
APPROVED	NAT 131	CAGE CODE	3AB01	PART NO.	AA21-400	REV. 1.01
FILE	403-0.DWG	DWG. TYPE	INTERCONNECT	DWG. NO.	AA21\400\403-0	SHEET 1/1

REVISIONS			
REV	DESCRIPTION	DATE	BY
1.01	ECR #1481 – CHANGED NOTES 1, 3 & 7; ADDED NOTES 8 & 9; FORMAT CHANGES.	SEP 26/00	TAT
1.10	DOCCR01476 – CHANGED TO SHOW OPTIONAL LO POWER PA CONNECTIONS. UPDATED TEMPLATE.	JUN 5/06	TAT

AA22-492 INSTALLATION NOTES

NOTES:

1. ALL WIRES SHOULD BE 22 AWG UNLESS OTHERWISE SPECIFIED. ALL UNSHIELDED WIRE SHALL BE SELECTED IN ACCORDANCE WITH AC43.13-1B CHANGE 1, PARAGRAPHS 11-76 THROUGH 11-78. WIRE TYPES SHOULD BE TO MIL-W-22759 AS SPECIFIED IN AC43.13-1B CHANGE 1, PARAGRAPHS 11-85, 11-86 AND LISTED IN TABLE 11-11. ALL SHIELDED WIRE/CABLE SHOULD BE IN ACCORDANCE WITH MIL-C-27500.
2. OPTIONAL. PARALLEL TO HEADPHONE (1 ONLY) CONNECTION FOR MONITORING RADIOS VIA EXTERNAL P.A. SPEAKER.
3. OR CARBON-EQUIVALENT/AMPLIFIED DYNAMIC MICROPHONE.
4. MIC INPUT LO (PIN 25) MUST GO TO EXTERNAL GROUND TO EXCITE MICROPHONE, IF NOT PROVIDED BY AUDIO SYSTEM.
5. FOR CYCLIC-SWITCH KEYING, WIRE AS SHOWN. FOR FRONT-PANEL AUTO-KEYING, GROUND PIN 10.
6. SHIELD TO REDUCE INTERFERENCE WITH OTHER SYSTEMS.
7. ISOLATED TRANSFORMER OUTPUT. 'AUDIO OUT LO' MUST BE TERMINATED AT P1 'C'.
8. SWITCH POWER OUT (PIN 8) RATED 400mA @ 28VDC.
9. K1 RELAY NAT P/N 65-80-200 OR EQUIVALENT. FLT1 RF FILTER NAT P/N 22-00-003A OR EQUIVALENT.
10. UP TO 5W PA INPUT FROM EXISTING SYSTEM.

DEFINITIONS:

- N/C: NO CONNECTION. THE PIN IS NOT CONNECTED TO ANYTHING INTERNALLY, AND THEREFORE SHALL HAVE NO CONNECTION EXTERNALLY.
- N/C SPARE: NO CONNECTION INTERNALLY, BUT A SPARE WIRE SHALL BE INSTALLED IN THE WIRE HARNESS.
- RESERVED: MAY BE CONNECTED AND USED IN THE FUTURE. THE CIRCUITRY MAY BE PRESENT OR ADDED TO ACTIVATE THE FUNCTION. THE PIN MAY BE USED FOR TEST PURPOSES. THERE IS NO EXTERNAL CONNECTION.
- RESERVED SPARE: RESERVED, BUT INSTRUCTIONS SHALL BE FOLLOWED TO ACTIVATE THE CIRCUITRY. A SPARE WIRE SHALL BE INSTALLED IN THE WIRE HARNESS.

CONFIDENTIAL AND PROPRIETARY TO NAT LTD.

DESIGNED	RL	 NAT NORTHERN AIRBORNE TECHNOLOGY LTD.				
DRAWN	TAT					
DATE	MAY 26/06	TITLE PA/SIREN SYSTEM				
CHECKED	NAT 255					
APPROVED	NAT 131	SIZE	CAGE CODE	PART NO.	REV.	SHEET
		A	3AB01	AA22-492	1.10	1/3
FILE	403-0.DWG	DWG. TYPE	INTERCONNECT	DWG. NO.	AA22\492\403-0	

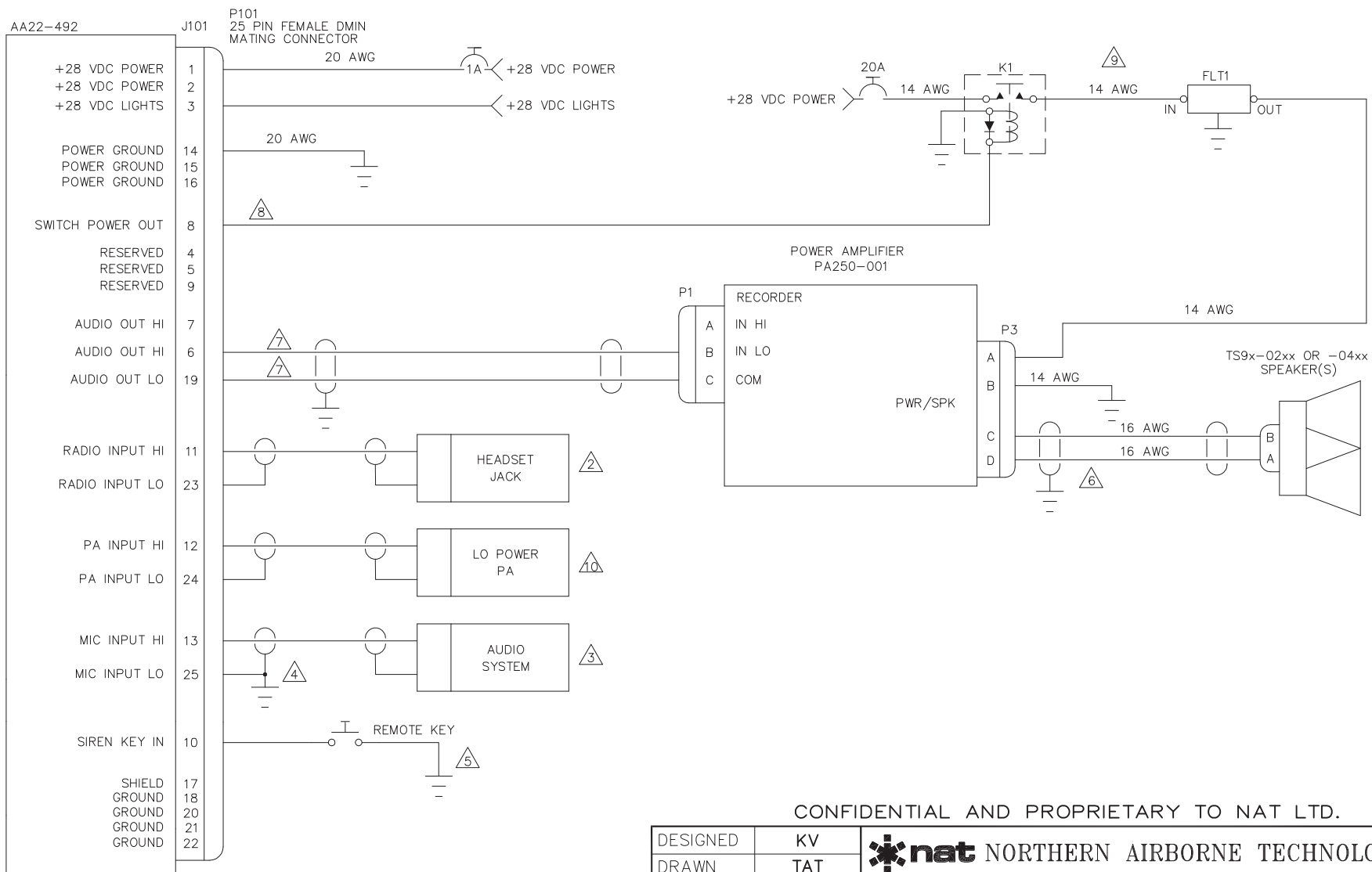

CONFIDENTIAL AND PROPRIETARY TO NAT LTD.

DESIGNED	KV	 NAT NORTHERN AIRBORNE TECHNOLOGY LTD.				
DRAWN	TAT					
DATE	SEP 19/02	TITLE				
CHECKED	NAT 255	PA/SIREN SYSTEM 250 WATT				
APPROVED	NAT 131	SIZE	CAGE CODE	PART NO.	REV.	SHEET
		A	3AB01	AA22-492	1.10	2/3
FILE	403-0.DWG	DWG. TYPE		INTERCONNECT	DWG. NO. AA22\492\403-1	

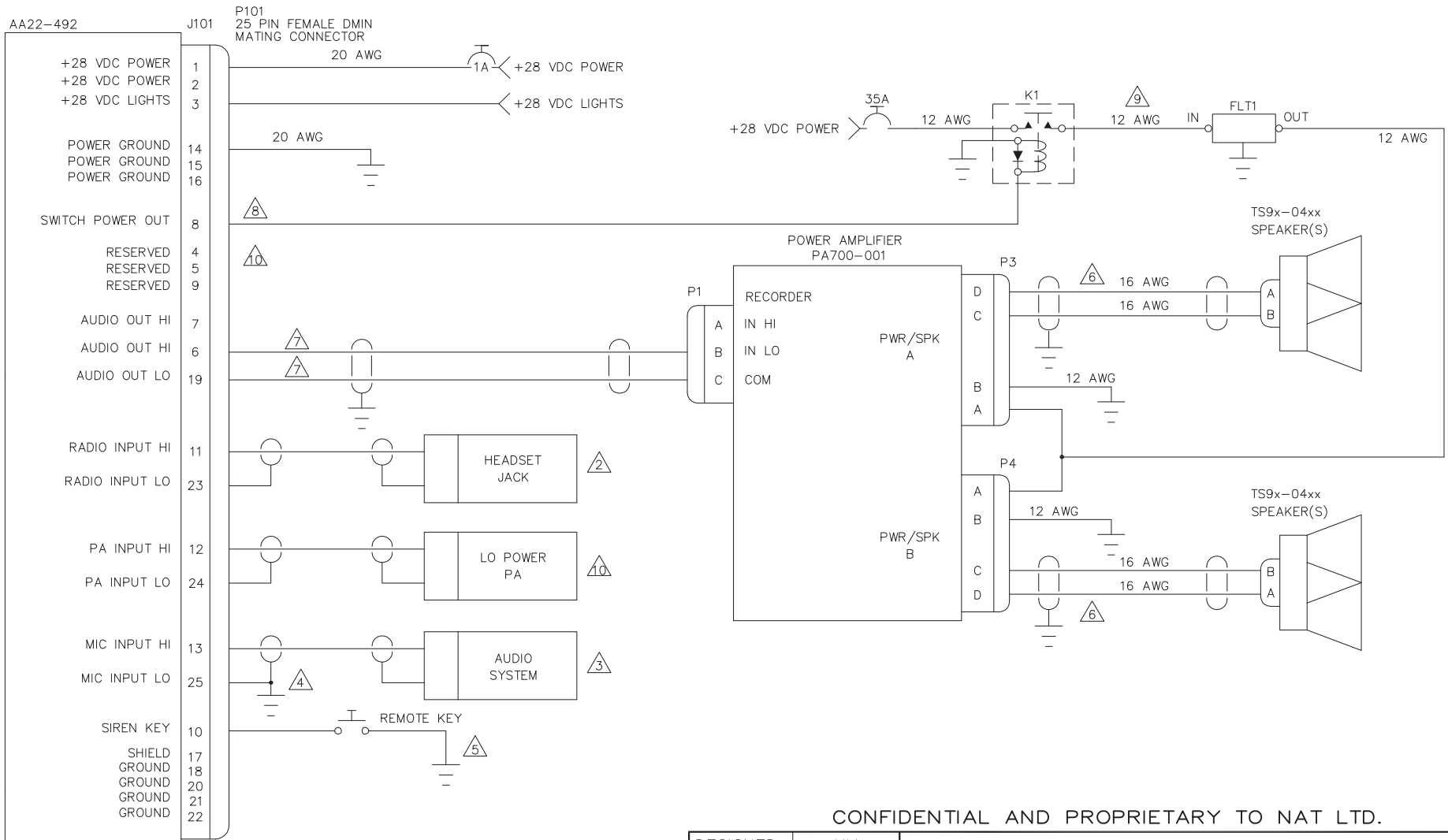

CONFIDENTIAL AND PROPRIETARY TO NAT LTD.

DESIGNED	KV	NAT NORTHERN AIRBORNE TECHNOLOGY LTD.				
DRAWN	TAT					
DATE	SEP 19/02	TITLE				
CHECKED	NAT 255	PA/SIREN SYSTEM 700 WATT				
APPROVED	NAT 131	SIZE	CAGE CODE	PART NO.	REV.	SHEET
		A	3AB01	AA22-492	1.10	3/3
FILE	403-0.DWG	DWG. TYPE	INTERCONNECT	DWG. NO.	AA22\492\403-2	

PA250-001
AMPLIFIER

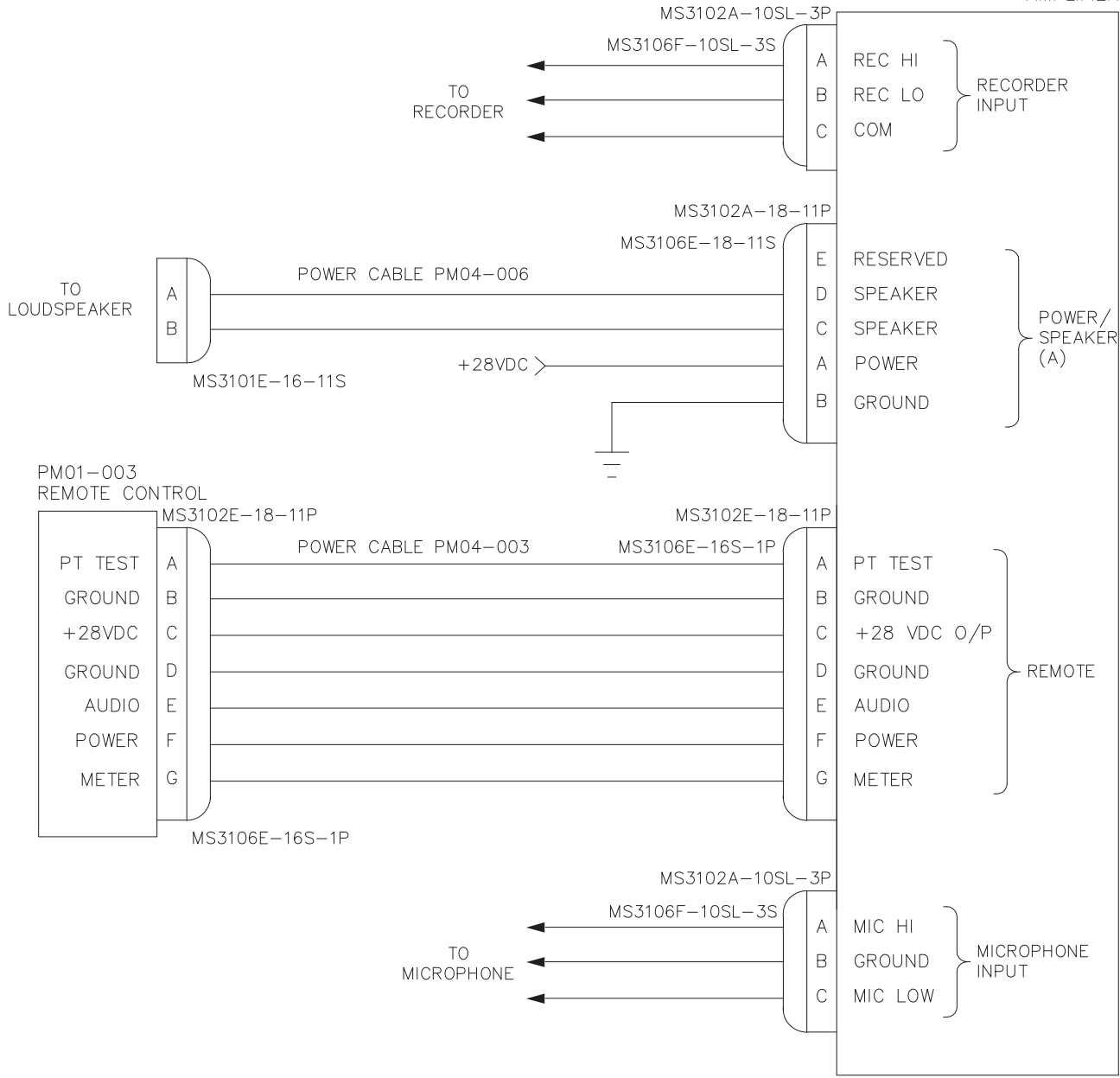

PROPRIETARY AND CONFIDENTIAL TO NAT LTD.

DESIGNED	-	 NAT NORTHERN AIRBORNE TECHNOLOGY LTD.						
DRAWN	MWS							
DATE	OCT 12/00	TITLE						
CHECKED	<table border="1"> <tr> <td>NAT 231</td> <td>NAT 223</td> </tr> </table>	NAT 231	NAT 223	PA250 AMPLIFIER				
NAT 231	NAT 223							
APPROVED	<table border="1"> <tr> <td>NAT 107</td> </tr> </table>	NAT 107	SIZE A	CAGE CODE 3AB01	PART NO. PA250	REV. 1.00	SHEET 1/1	
NAT 107								
FILE	407-0100.DWG	DWG. TYPE	CABLING DIAGRAM	DWG. NO.	PA250\407-0			

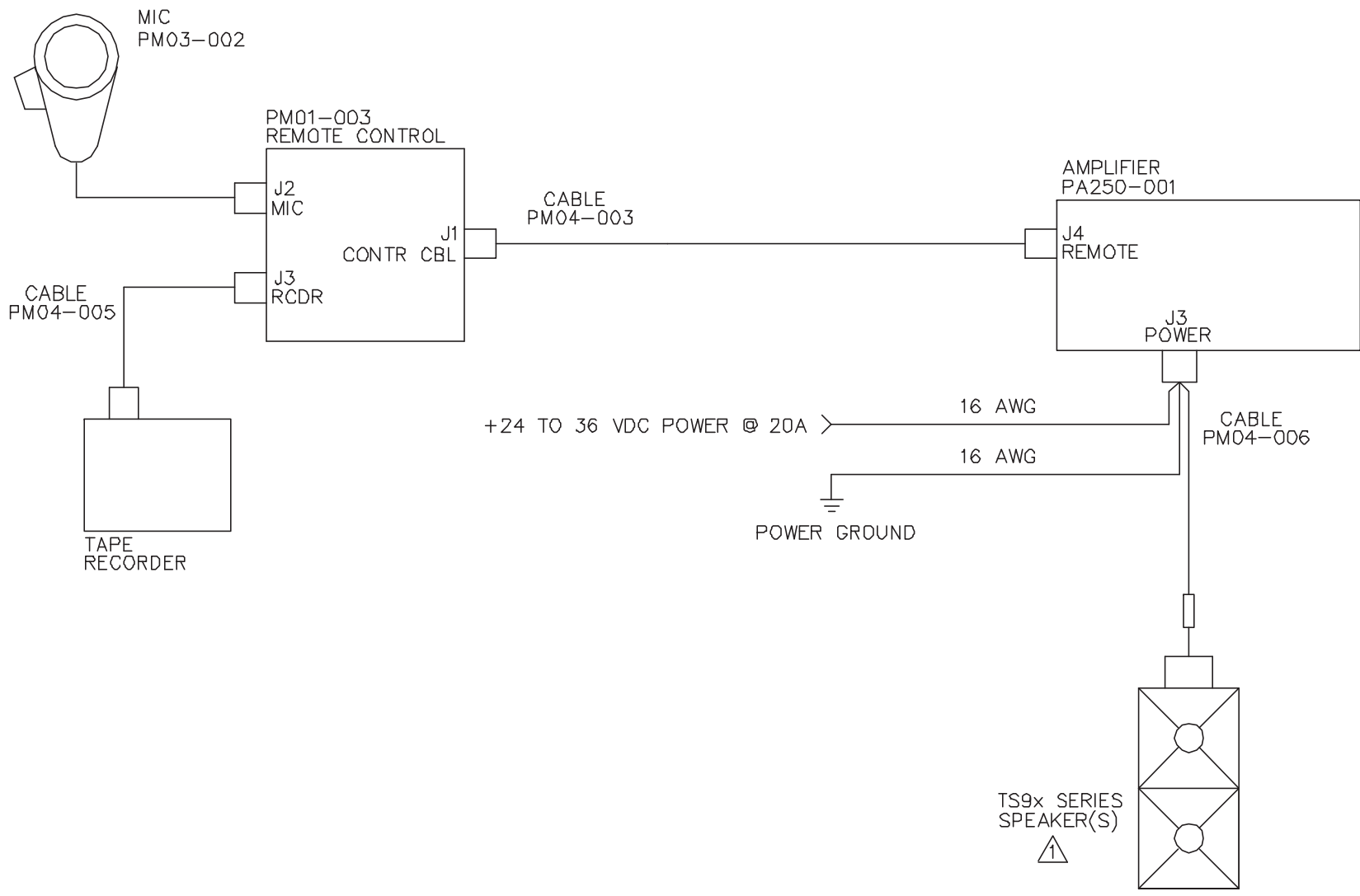

NOTES:
 ⚠ CONSULT FACTORY FOR SPEAKER CONFIGURATION OPTIONS.

PROPRIETARY AND CONFIDENTIAL TO NAT LTD.

DESIGNED	JD	NAT NORTHERN AIRBORNE TECHNOLOGY LTD.				
DRAWN	TAT					
DATE	AUG 17/00	TITLE 250 WATT SYSTEM				
CHECKED						
APPROVED		SIZE	CAGE CODE	PART NO.	REV.	SHEET
FILE	407-0100.DWG	A	3AB01	PA250-001	1.00	1/1
DWG. TYPE		CABLE DIAGRAM		DWG. NO. PA250\001\407-0		

REVISIONS

REV	DESCRIPTION	DATE	BY
2.00	ECR#1454 MAJOR REDESIGN FOR MANUFACTURABILITY	MAR 28/03	MWS
2.10	DOCCR02509 - ADD'D ESD & WARRANTY VOID LBL'S.	JUN 05/08	MWS

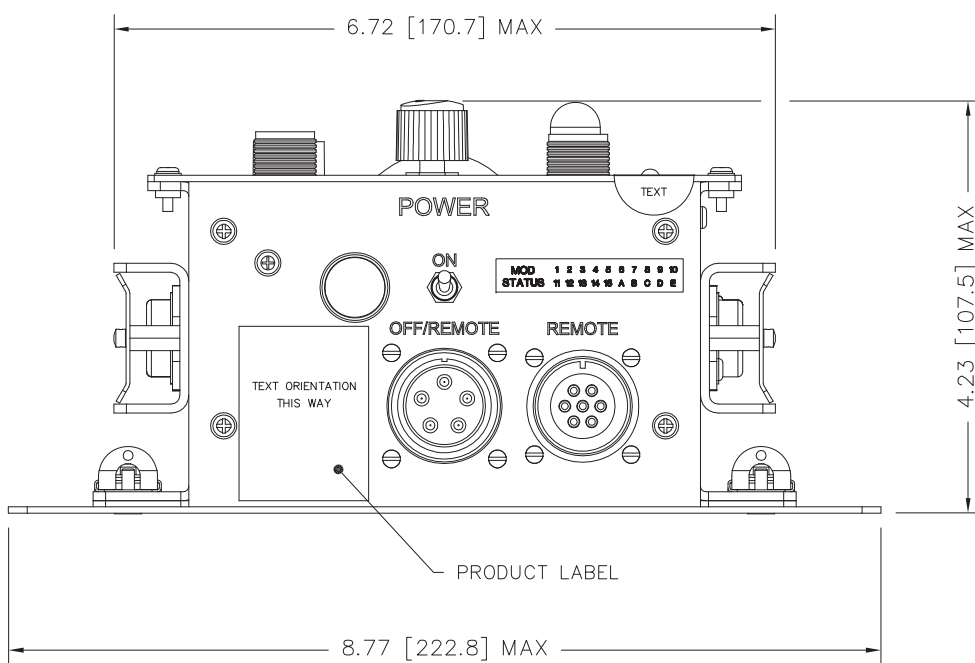
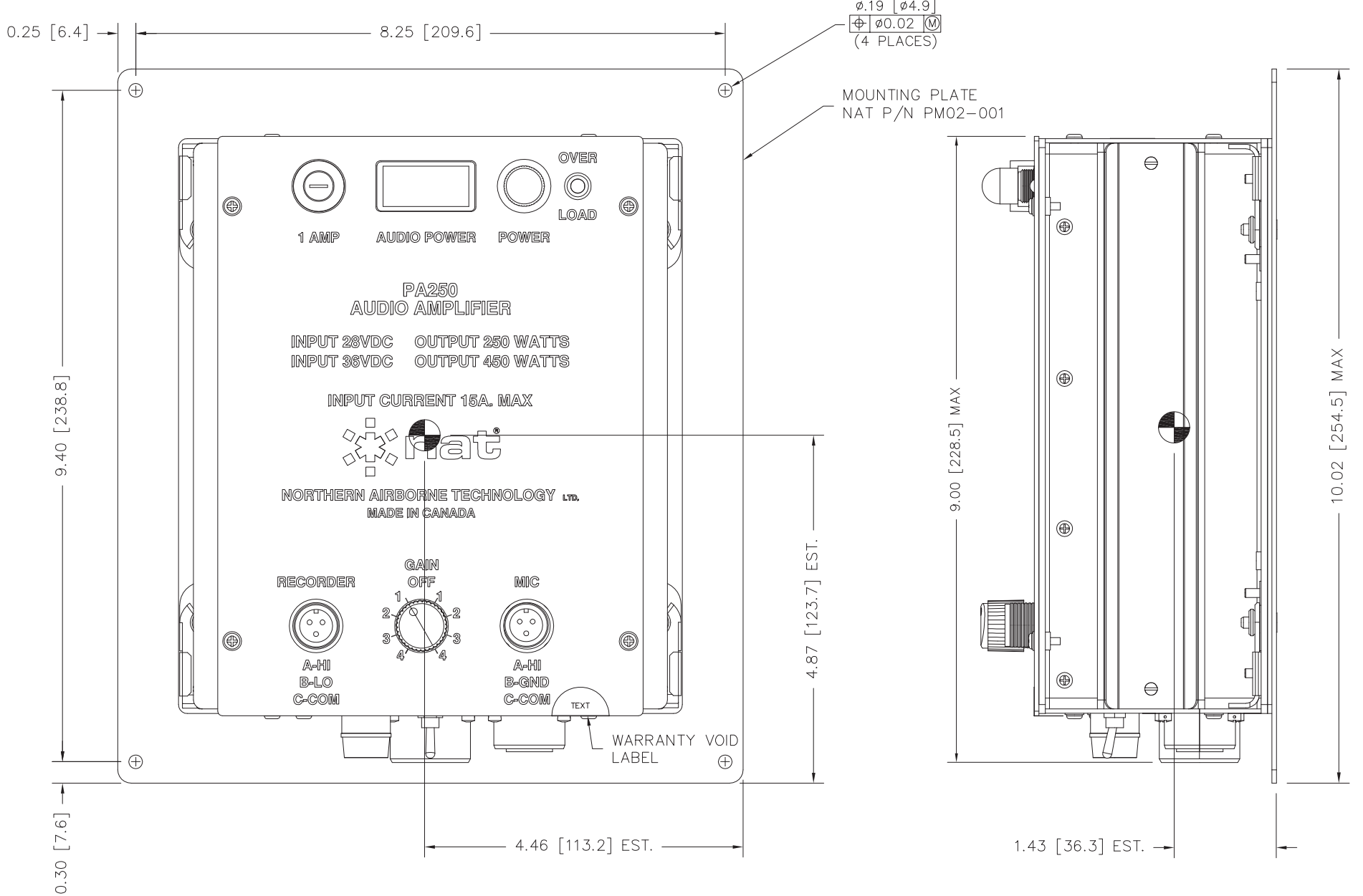
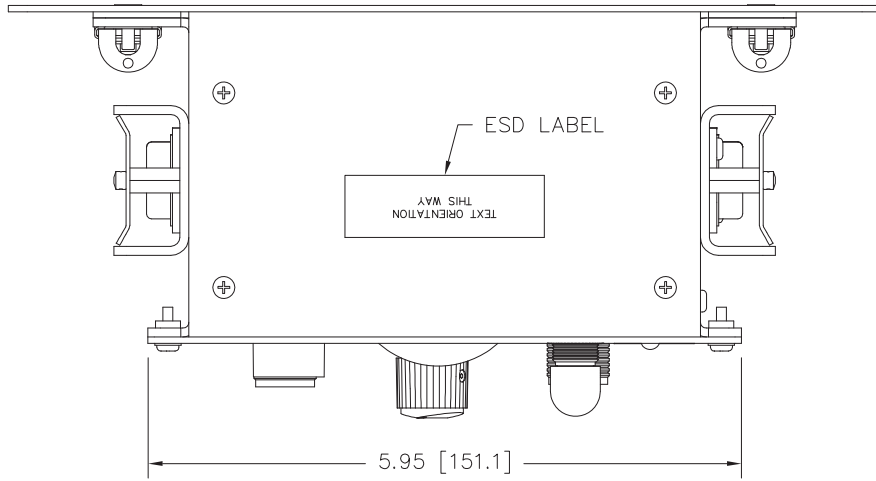

NOTES:
1. DIMENSIONING AND TOLERANCING
IN ACCORDANCE WITH ASME Y14.5M-1994

CONFIDENTIAL AND PROPRIETARY TO NAT LTD.

DIMENSIONS ARE INCHES [mm]	DESIGNED	-	NORTHERN AIRBORNE TECHNOLOGY LTD.				
	DRAWN	MWS/TAT					
THIRD ANGLE PROJECTION	DATE	APR 20/99	TITLE				
MASS: 7.4 lbs. (3.3 kg) MAX	CHECKED	NAT 255	AUDIO POWER AMPLIFIER				
	MATERIAL	-					
FINISH	APPROVED	NAT 131	SIZE	CAGE CODE	PART NO.	REV.	SHEET
BLACK ANODIZED	FILE	922-0200.DWG	B	3AB01	PA250-001	2.10	1/1
			DWG. TYPE	MECH. INSTALLATION	DWG. NO.	PA250\001\922-0	



PA250 Series High Power Voice Amplifier SM44-1 Installation and Operation Manual

Section 3.0 Operation

3.1 Introduction

Information in this section consists of functional and operational procedures for the PA250 Series High Power Voice Amplifier.

3.2 General Information

The PA250 Series is built within an aluminum chassis, which provides a rugged case and an excellent heat sink. Removable side panels protect the power components mounted between the cooling fins from accidental contact with metallic objects. These panels are easily removed to gain access to the components. Operating features are the Press-to-Test indicator lamps, the gain control, the microphone and recorder input connectors, the POWER switch and the power-input / speaker-output connectors.

3.3 Controls and Indicators

Controls and indicators are shown in Figure 1 and will be described in more detail in this section.

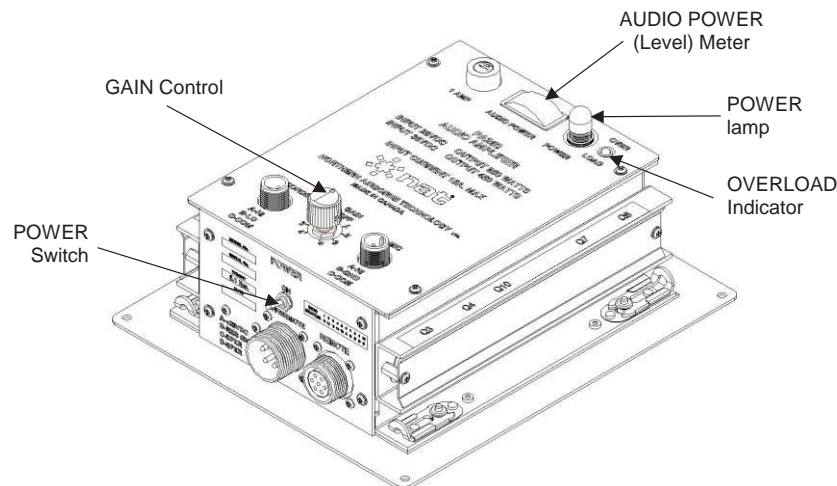

Figure 1: Controls and Indicators

3.3.1 POWER Switch

The PA250 Series is switched on by setting the POWER switch to the 'up' position (ON).

If the installation uses a remote control (AA21/AA22 or PM01), the 'power on' selection will be made at the remote control.

For a PM01 type remote control, the POWER switch on the PA250 should be set to 'OFF/REMOTE'. If the installation uses an AA21/AA22 type remote control, the POWER switch should be set to 'ON'.



PA250 Series High Power Voice Amplifier SM44-1 Installation and Operation Manual

3.3.2 POWER Lamp

The POWER lamp should illuminate red when the power switch is selected ON, the voltage and polarity of input power is correct and no protective circuit has tripped.

If the POWER lamp is pressed with the power switch off, it will illuminate red to indicate the presence of DC power at the input power receptacle.

Fluctuations in the intensity of the lamp during operation indicate a high impedance power source or a depleted battery in the unit.

3.3.3 GAIN Control

The GAIN control is a rotary switch used to adjust the gain of the unit. For specific operating information, see sections 3.3.3.1 and 3.3.3.2 below.

3.3.3.1 Operation with Microphone

For microphone operation the 'GAIN' control is adjusted clockwise from OFF until the level meter occasionally swings into the red area during a test count. If feedback is a problem it may be necessary to reduce the input 'Gain' control or preferably, improve the sound shielding of the microphone position.

Loudspeakers will overheat with a continuous signal at full power. Voice operation will generate less heat, and pauses between words result in a low-duty cycle.

3.3.3.2 Operation with Recorder

When a recorder or other external sound source is to be operated with the amplifier, connection is made to the recorder (REC) input connector.

The 'GAIN' control is rotated counterclockwise from the OFF position to increase the recorder input signal. Pins B - C will be used for a 600 Ohm source and Pins A - C will be used for a 2000 Ohm source as shown on the amplifier panel.

If the recorded sound is voice, the correct input level is adjusted in the same manner as for microphone operation. If the recorded sound is music, it is advisable to operate at a reduced 'GAIN' control setting. If the input signal is siren or trill, the GAIN should be set for maximum volume and the level meter will read continuously in the red area.

Failure to reduce the gain setting may cause excessive power to be dissipated in the speaker units and result in failure of the speaker voice coils due to overheating.

Fade operation can easily be performed between microphone and recorder inputs by adjusting the 'GAIN' control setting. This operation permits a smooth transition from voice input to tape/playback input and back again.

CAUTION:

With siren or trill signals, limit full power operation to periods of 15 seconds
ON/OFF to prevent damage to speakers.



PA250 Series High Power Voice Amplifier SM44-1 Installation and Operation Manual

3.3.4 AUDIO POWER (Level) Meter

The AUDIO POWER meter indicates the audio voltage going to the speaker load. The meter is calibrated so that the pointer will be in the red area of the display at full power with the proper load.

Note: If the load is incorrectly connected, an erroneous meter reading will be given.

3.3.5 OVERLOAD Indicator LED

The PA250 Series amplifier is designed with self-protecting circuitry to interrupt operation whenever unusual conditions exist which might endanger the amplifier components. Such conditions might be excessive voltage, a voltage spike, a speaker short or a temperature rise. The OVERLOAD indicator will illuminate red to notify the operator that the protective circuitry has been activated. See Section 3.3.6 for 'Reset' information.

3.3.6 Resetting the Protective Circuit

Once the protective circuit is activated, the OVERLOAD indicator LED will illuminate red and no further operation is possible without corrective action. If the trouble was due to a temporary or transitory cause, operation may be resumed by simply selecting the power switch to OFF and back to ON. If the protective circuit again shuts the amplifier off, the POWER switch should be turned off and the problem diagnosed and corrected before further use of the unit is attempted.

CAUTION:

The transistors of this system are subject to damage when exposed to excessive heat, voltage, or current for even short periods of time.

The PA250 Series incorporates a protective circuit, which disables the amplifier when safe operating currents or voltages are exceeded. The protective circuit is adequate in most instances however, it is also subject to damage when the unit is exposed to extreme or sustained stresses. Careful monitoring is therefore necessary when operating under unusual environmental extremes. Precautions should be taken to maintain temperature within recommended limits. Other damaging conditions are excessive battery charging voltages, short circuits within the system and transmission of compressed high level music resulting in continuous high-level power generation.

Operation at high temperature should be limited to short periods. Even at normal temperatures, operation at continuous full power (Level meter in the red) should be interrupted for 5–10 seconds at 15-second intervals.

Loudspeakers will overheat with a continuous signal at full power. Voice operation will generate less heat, and pauses between words will result in a low duty cycle.

Section 3.0 ends
