

GA182-7
Revision D, 4/23/2014
P139-HD Digital Audio System
AS350/355 Installation Manual



1.0 INTRODUCTION

- 1.1. This document provides general information and instructions for the installation of the Geneva P139-HD Digital Audio System, under STC SR00521SE.
- 1.2. Installation is to be accomplished in accordance with Geneva Aviation instructions. Throughout the installation of this product it is necessary to utilize proper aviation practices. Be sure that the installation of this product is in compliance with the aircraft manufacturer's limitations and also that it is done in accordance FAA publication, AC 43.13-1B, Acceptable Methods, Techniques and Practices, Aircraft Inspection and Repair. These rules from the AC apply :
 - A. All wire to be 22 AWG unless otherwise specified.
 - B. Unshielded wire per MIL-W-22759/16; Shielded wire per MIL-M27500-xxTGxT14 ; xx- indicates wire gauge, x- indicates number of conductors.
 - C. Route and support wiring harness IAW AC 43.13-1b, Chapter 11 Section 8, Paragraph 11-96.
 - D. Clamp wiring harness IAW AC 43.13-1b, Chapter 11, Section 11, Paragraph 11-146.
 - E. Clamp and route wiring harness around movable controls IAW AC 43.13-1b, Chapter 11, Section 9, Paragraph 11-125.
 - F. Wiring and harness to be separated IAW AC 43.13-1b, Chapter 11, Section 8, Paragraph a 11-105 & 11-106.
 - G. Install service loops at harness terminations IAW AC 43.13-1b, Chapter 11, Section 9, Paragraph 11-139.
 - H. Install grounding connections and bonding IAW AC 43.13-1b, Chapter 11, Section 15, Paragraph 11-186 & 11-189.

Before installing any of the components, first read through all of the documentation to become familiar with the installation requirements. This installation requires a completed FAA Form 337 and appropriate log book entries.

Prior to installing each component, record weight and mounting location in the aircraft's weight and balance record.

This product is provided with an FAA STC for certain aircraft models. If your installation is not covered by one of the models listed on the STC, then you may need to obtain a field approval from your local FAA Flight Standards District Office (FSDO).

The P139-HD Digital Audio Router contains no user serviceable internal components. Do not disassemble router or the factory warranty will be voided. For service, return the unit to Geneva Aviation.

- 1.3. There are three types of P139-HD Audio Systems that the installer may choose to install at their discretion.
 - 1.3.1. P139-HD (D) Uses Router G13000 in a “Dual-board” configuration and is shown in the diagrams and is the router used throughout the instructions.
 - 1.3.2. P139-HD (S) Uses Router G13000 in a “Single-board” configuration that uses the same case as the dual-board router, but with only one audio board installed. These two routers share the same installation and wiring drawings.
 - 1.3.3. P139-HD (T) uses Router G13160 and is a “Three board” router. This installation replaces wiring drawing G13004 with drawing G13162. Installation of this router is performed the in the same manner as the other two routers with slight changes in the mounting hardware as noted in the instructions.
- 1.4. Prior to installation of this system, it is the responsibility of the installer to confirm by analysis or measurement, that the additional power requirement will not exceed the capacity of the avionics bus or the aircraft’s electrical system. Power consumption for this audio system is 5 amps at 28 volts. The system is designed to use redundant power sources, both coming from the master avionics bus. For each supply line, use a separate 5 amp fuse or circuit breaker on a 28 volt aircraft and separate ground lines to two separate ground points. Refer to G13004 for wire harness details. The system will support supply voltages of 14 – 32 VDC.
- 1.5. The internal power supply of the router is sufficient to power six audio control panels. If the installation calls for more than six panels, the additional panels must be powered from a separate circuit breaker to the Router. Refer to G13004 sheet 12 for more information.
- 1.6. The FAA requirement regarding the securing of wire bundles using nonmetallic clamps is addressed by the use of nylon cable ties. The part numbers and description of these ties is as follows:

Following the guidelines in AC43.13-1B, cable ties are attached at a maximum of 4” spacing and ties are attached to nylon cable tie anchors, as necessary.

Cat. No.	UPC	Body Width In.	Length In.	Max. Wire Bundle Dia. In.	Military Standard Part No.	Tensile Strength Lb.
TY23M	82436	.091	3.62	.625	MS3367-4	18
TY24M	82447	.140	5.50	1.125	MS3367-5	40
TY25M	82457	.184	7.31	1.750	MS3367-1	50

- 1.7. The aircraft into which this product will be installed may be a new aircraft or an aircraft that has been in service. The configuration of the wiring and cabling will vary from aircraft to aircraft. The installation of the Geneva Aviation Audio System should use existing wire and cable runs when possible as it will not interfere with the existing aircraft wiring.
- 1.8. These instructions call out cables by reference to the drawing that defines the cable construction details. The installer may, at the installer's discretion, substitute connectors, wire type, and connection details, so long as the final installations operate correctly and meets FAA standards.
- 1.9. The Router features a COM1 Isolate mode that automatically connects the pilot's headset and mic switches directly to COM1 in the event of power loss or failure of the Audio Router. The pilot may also activate the COM1 Direct mode using the EMERG/NORMAL switch on the G13115 and G13116 control panels. This feature may also be set up for the Copilot to activate a COM2 Isolate mode using the EMERG/NORMAL switch on the copilot control panel.
- 1.10. For Non-Pilot positions, Control Panels G13115NS or G13116NS may be used. The panels do not have an internal COM1, COM2 isolate switch. For these panels, do not connect to the COM1 or COM2 circuits shown in wiring diagrams G13004.

2.0 System Overview

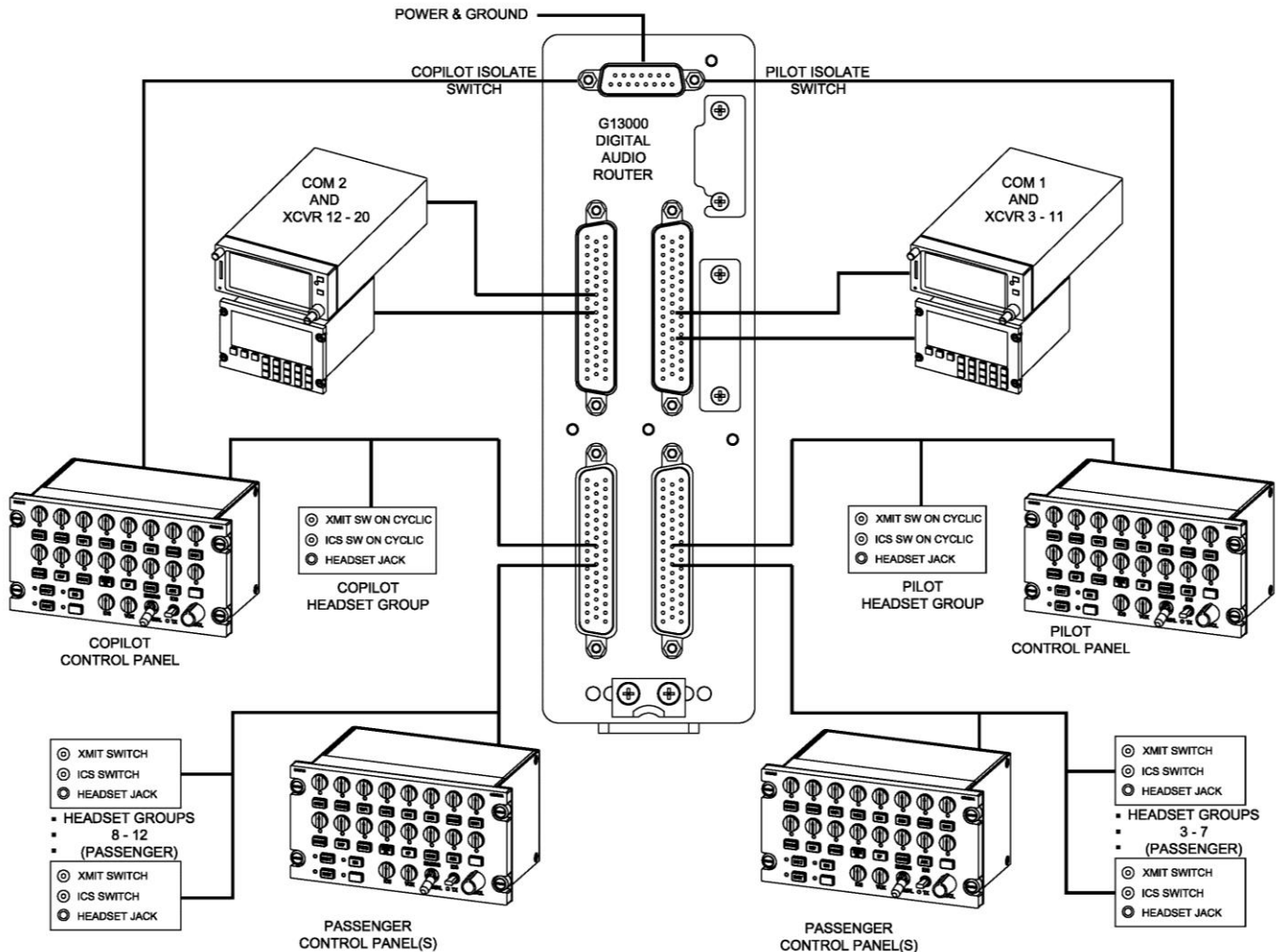

Figure 1

Digital Audio System Overview

- 2.1. The schematic shown in Figure 1 is a typical system. The installer may, at the installer's discretion, add or remove radios, control panels, headset groups, or ICS and Transmit PTT switches as needed.
- 2.2. Control Panels G13115 and G13116 may be used interchangeably, depending on the control functions desired and number of radios installed.
- 2.3. It is the installer's responsibility to document the system configuration as installed for maintenance purposes.

3.0 Component Installation & Hookup

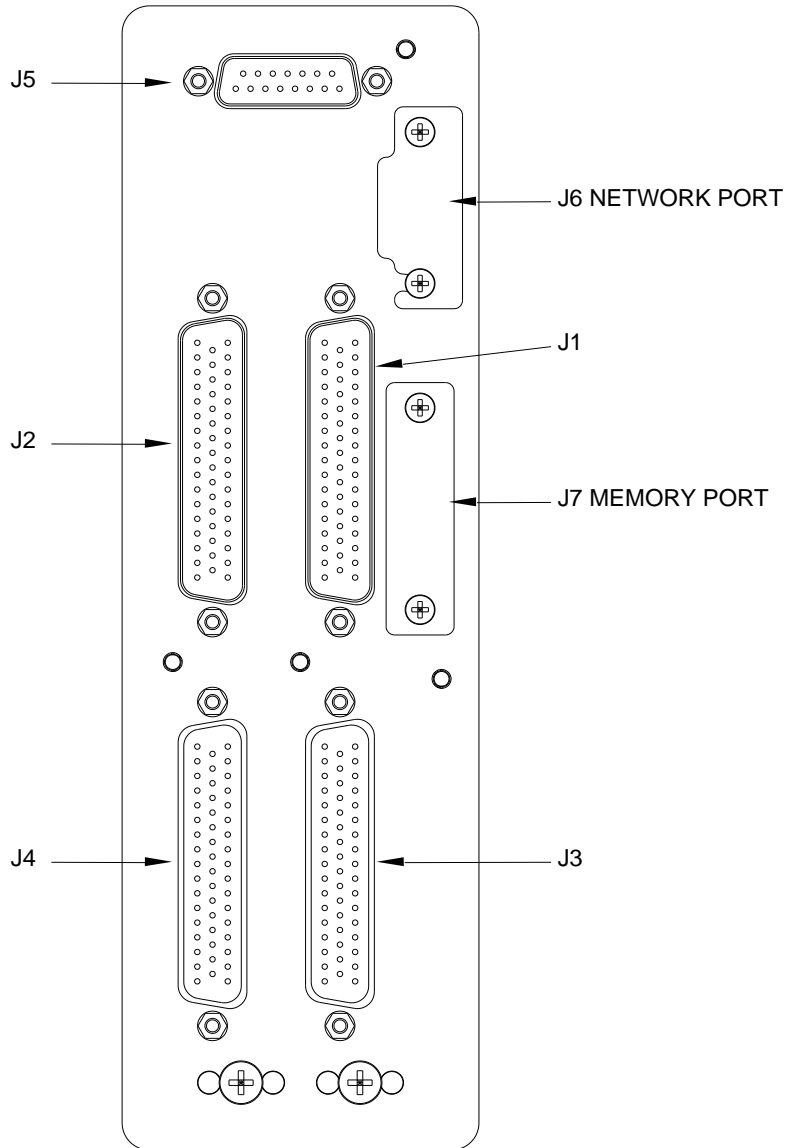

Figure 2
G13000 Router Connector Layout

3.1. G13000 Router Connections (see Figure 2)

- 3.1.1. J1 is used to connect COM1 and radios XCVR3 – XCVR11.
- 3.1.2. J2 is used to connect COM2 and radios XCVR12 – XCVR20.
- 3.1.3. J3 is used to connect the Pilot's control panel, Pilot's headset group, headset groups 3 – 7 and passenger control panels.
- 3.1.4. J4 is used to connect the Copilot's control panel, Copilot's headset group, headset groups 8 – 12 and additional passenger control panels.
- 3.1.5. J5 is used to connect power, ground, Pilot's COM1 Isolate, and Copilot's COM2 Isolate.
- 3.1.6. J6 is a network port used for system configuration adjustment.
- 3.1.7. J7 is a memory card slot used for storing system configuration data onto removable media.
- 3.1.8. The Router contains no user serviceable internal components. Do not disassemble router or the factory warranty will be voided. Return the unit to Geneva Aviation for service.

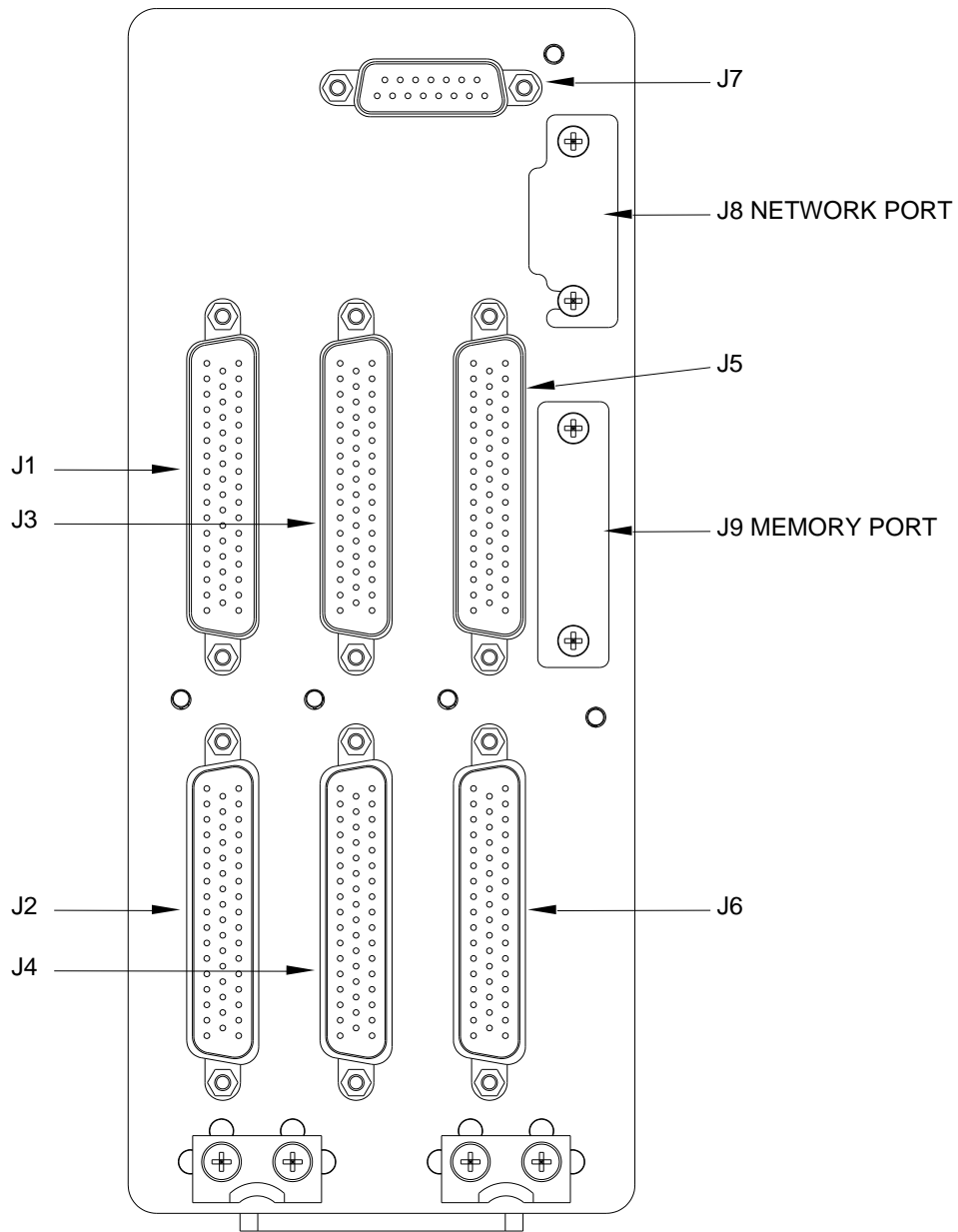
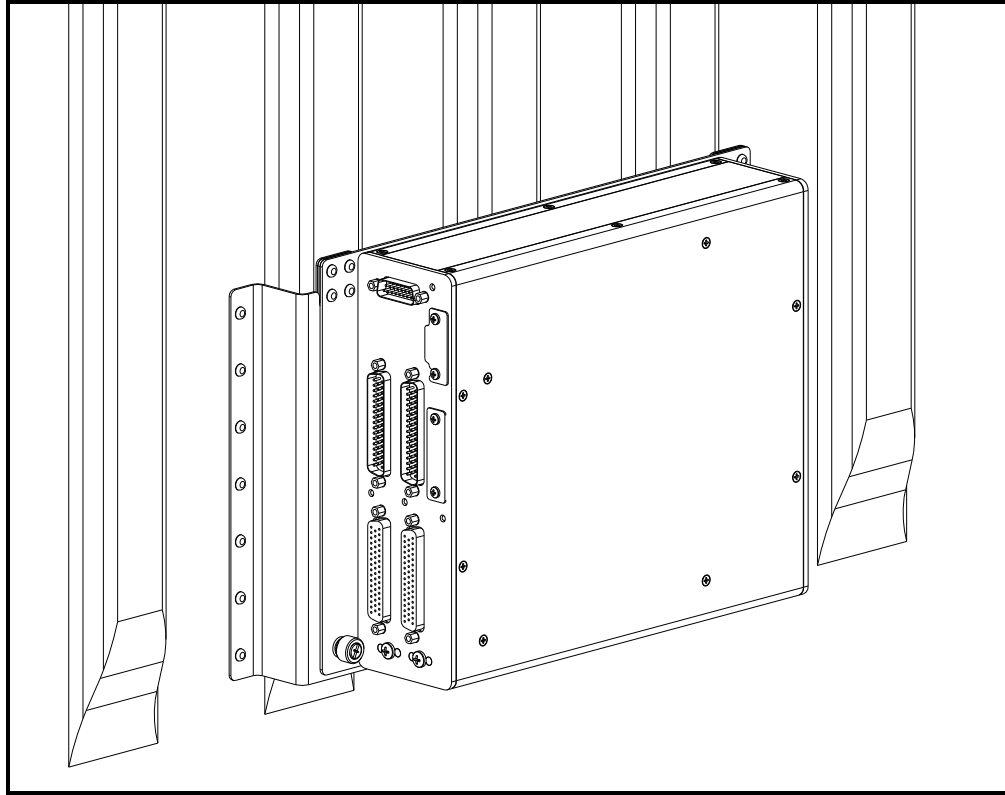

Figure 3
G13160 Router Connector Layout

3.2. G13160 Router Connections (see Figure 3)

- 3.2.1. J1 is used to connect radios COM1 and radios XCVR3 – XCVR11.
- 3.2.2. J2 is used to connect the Pilot's control panel, Pilot's headset group, headset groups 3 – 7 and passenger control panels.
- 3.2.3. J3 is used to connect radios COM2 and radios XCVR12 – XCVR20.
- 3.2.4. J4 is used to connect the Copilot's control panel, Copilot's headset group, headset groups 8 – 12 and additional passenger control panels.
- 3.2.5. J5 is used to connect radios XCVR21 – XCVR30.
- 3.2.6. J6 is used to connect headset groups 13 – 18 and additional passenger control panels.
- 3.2.7. J7 is used to connect power, ground, Pilot's COM1 Isolate, and Copilot's COM2 Isolate.
- 3.2.8. J8 is a network port used for system configuration adjustment.
- 3.2.9. J9 is a memory card slot used for storing system configuration data onto removable media.
- 3.2.10. The Router contains no user serviceable internal components. Do not disassemble router or the factory warranty will be voided. Return the unit to Geneva Aviation for service.

3.3. Component Installation & Hookup



Router Installation in Aft Baggage Compartment

- 3.3.1. Refer to drawing G13005 for installing the Router into the Aft Baggage compartment. Router G13000 is shown in drawing G13005 and in the figure above. Router G13160 may be installed in place of G13000 using the same methods and hardware define in drawing G13005.

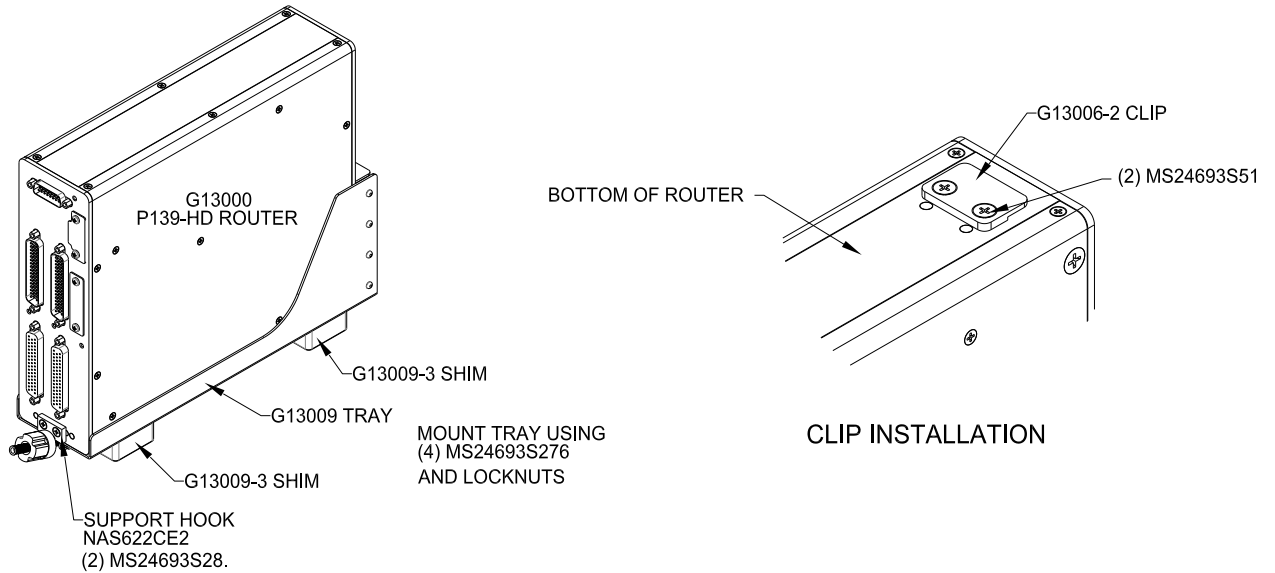

Figure 4

- 3.3.2. Optional: The installer may install the Router onto an avionics shelf or bay with a 5 lb. minimum load rating. Install using hardware shown in Figure 4.
- 3.3.3. Note: for the G13160 Router replace in Figure 3 the following items: G13009 with G13161; G13009-3 with G13161-3; G13006-2 with G13161-4 and use (3) MS24693S51 screws to install; use (2) NAS622CE2 Support Hooks.
- 3.3.4. For Router G13000, refer to drawing G13004 for the detailed wiring schematic used in this installation. For Router G13160, refer to drawing G13162 for the detailed wiring schematic used in this installation.
- 3.3.5. Be sure to carefully document the Radios and Control panels as installed and their related connections for future maintenance and troubleshooting purposes.

3.4. Control Panels

- 3.4.1. The Control Panels mount onto standard DZUS rails and should be mounted in locations designed for standard avionics mounting. The control panels connect to the router via the 4-wire GNET bus.
- 3.4.2. There can be more than one of these control panels in any combination connected to the system. Each audio board has two GNET ports giving 2, 4, 6 GNET ports for the P139 (S)/(D)/(T) routers respectively. If the configuration calls for more control panels than there are available GNET ports on the router, connect J1 of each control panel to a GNET port in parallel for pins 1 – 4. Pins 5 – 9 will be unique ID for each control panel connector. See G13004 sheet 9 for details.
- 3.4.3. The pilot control panel also controls the COM1 Isolate function. Optionally the copilot control panel controls the COM2 isolate function. See Section 1.8 for more information.

3.5. Control Panels G13115 & G13115NS



- 3.5.1. The G13115 & G13115NS Control panels provide separate transmit, receive and volume controls for up to 16 radios or other devices, as well as crew intercom functions and optionally installer-defined special functions. The G13115NS version does not have an EMERG/NORMAL switch and must not be used as a pilot or copilot primary panel.

3.6. Control Panels G13116 & G13116NS



- 3.6.1. The G13116 & G13116NS Control panels provide separate transmit, receive and volume controls for up to 8 radios or other devices, as well as crew intercom functions and optionally installer-defined special functions. The G13116NS version does not have an EMERG/NORMAL switch and must not be used as a pilot or copilot primary panel.

3.7. Headset Ports

- 3.7.1. The Pilot and Copilot Headset Group consists of the headset jack, ICS switch and transmit switches on the cyclic and/or foot switches.
- 3.7.2. For each passenger, a unique Passenger Headset Group is needed. The Passenger Headset Group consists of the passenger's headset jack, an ICS switch and a transmit switch.

3.8. COM1, COM2 and other radio ports

3.8.1. The G13000 digital audio router supports up to 20 radios and the G13160 router supports up to 30 radios. Each radio should be installed in accordance with the manufacturer's instructions.

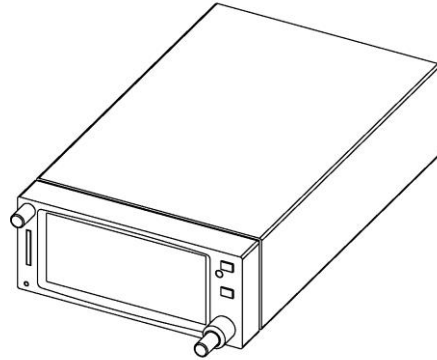

3.8.2. For the G13000 the following connections are available:

3.8.2.1. The COM1 radio connects to J1 on the Router along with radios XCVR3 - XCVR11 (refer to G13004 sheet 4).

3.8.2.2. The COM2 radio connects to J2 on the router along with radios XCVR12 - XCVR20 (refer to G13004 sheet 5).

3.8.3. For the G13160 the following connections are available:

3.8.3.1. The COM1 radio connects to J1 on the Router along with radios XCVR3 - XCVR11 (refer to G13162 sheet 5).

3.8.3.2. The COM2 radio connects to J3 on the router along with radio ports XCVR12 - XCVR20 (refer to G13162 sheet 6).

3.8.3.3. Radios XCVR21 - XCVR30 connect to J5 on the router (refer to G13162 sheet 7).

3.8.4. While the term radio is used throughout this document, any type of audio device can be connected, such as tape recorders, scanners, telephones, hand-held radios, etc.

There is normally no need for any type of universal radio adapter between an audio device and the router.

4.0 Functional Check

- 4.1. Perform a check of all power and ground leads to confirm they are connected properly before applying power to the system. Incorrect wiring may cause damage to the units.
- 4.2. Connect headset adapter cables, headsets and switches. Apply power to audio system, radios and related accessories. Activate ICS and confirm proper operation. Place 'PILOT EMERG/NORMAL' switch in 'EMERG' position. Key transmit switch and confirm proper operation of COM1.
- 4.3. Place the 'PILOT EMERG/NORMAL' switch in 'NORMAL' position and check all transceivers, receivers and audio devices.
- 4.4. If the system is equipped with a 'COPILOT EMERG/NORMAL' switch, repeat the steps in sections 4.2 and 4.3 for Copilot position and COM2 respectively.
- 4.5. Check all pilot, copilot and passenger audio control panels for proper audio levels and operation. Should adjustments be required, follow the instructions in document GA063-3.

5.0 Load Analysis

- 5.1. At the completion of the installation of the audio system, the installer shall perform a load analysis test of the electrical branch circuit that powers the audio system, and also the entire aircraft electrical load, to confirm that the addition of the audio system will not cause an overload to the electrical branch circuit or the aircraft generator.
- 5.2. The current shall be measured using a properly calibrated ammeter. A clamp-on amp meter, such as Amprobe Instrument model number ACDC-600A, or equivalent will make this job easier.
- 5.3. Perform the branch circuit load analysis test by powering up all equipment that is intended to be operated at the same time on the branch circuit that the audio system is connected to. Additionally, key the three highest power communication transmitters at the same time, if possible, while the current measurements are being taken.
- 5.4. Measure the current of the branch circuit powering the audio system, by clamping the meter around the branch circuit wire near its origin. Confirm that the current draw during the above described test conditions is less than the current limiter (fuse or circuit breaker) rating for that branch circuit.
- 5.5. If the current draw is greater than the current limiter rating, it becomes the installer's responsibility to re-distribute some of the other equipment powered by this branch circuit to another suitable branch circuit, in order to reduce the load on the audio system's branch circuit to less than the current limiter rating.
- 5.6. Once the branch circuit loads are within limits, test the current load for the entire aircraft while all power for the aircraft is being supplied by the aircraft generator, battery, or external power source. Perform this load analysis test by powering up all equipment on the aircraft that is intended to be operated at the same time as the audio system. Additionally, key the three highest power communication transmitters at the same time, if possible, while the current measurements are being taken. Clamp the ammeter around the power source. Confirm that the current draw during the above described test is less than the generator rating.
- 5.7. Upon satisfactory completion of these load analysis tests, make an aircraft logbook entry that these tests have been performed satisfactorily in accordance with this STC.

6.0 Interference Test Procedure

6.1. Perform electrical interference test using GA1-2TP test procedure.

7.0 Final Inspection

7.1. Perform final inspection of installation confirming:

- 7.1.1. There are no chaffing issues.
- 7.1.2. There are no mechanical interference issues.
- 7.1.3. Security of fasteners.
- 7.1.4. Removal of all tools.
- 7.1.5. Chips, shavings and other debris are removed.
- 7.1.6. Proper reassembly of aircraft.
- 7.1.7. Aircraft is airworthy prior to returning to service.

8.0 FAA Requirements

8.1. Amend the weight and balance records and make the necessary log book entry. Complete an FAA form 337 showing the installation of this equipment in accordance with the STC instructions and submit one copy to the FAA and one copy to the aircraft owner. File all data and a copy of the STC with the aircraft records.

LOG OF REVISIONS

REVISION LEVEL	DATE OF REVISION	PAGES	DESCRIPTION OF CHANGE	APPROVAL
--	11/05/08	All Pages	Initial Release	CLB
A	1/13/12	All	Revised Figure 3 showing new style tray	CLB
B	6/25/12	ALL	Updated 1.7, & 3.3 for G13115 & G13116	CLB
C	10/15/12	3, 9	Added 1.8; Added G13115NS and G13116NS to 3.3	CLB
D	4/23/14	ALL	Added G13160 3-Board Router	CLB