



G13000R Digital Audio Router P139-HD Installation and Operation Manual Supplement

This supplement contains installation and operation information that is unique to the G13000R Digital Audio Router. Installation and operation information common to the G13000 unit can be found in the P139-HD Installation Manual and the P139-HD Digital Audio System User Manual.

Prepared By:	Checked By:	Approved By:

Section 1.0 Description

1.1 Product Description

The G13000R Digital Audio Router is identical to the G13000 with the following exceptions:

- a) The G13000R has a physically reduced mechanical outline with two mounting orientations, wide and narrow for added flexibility.
- b) The G13000R has reduced the number of available Headset output and Radios.
- c) The G13000R has an integrated 25W speaker amplifier.

1.2 Product Approval/Certification

The G13000R currently has no STC or TSO certification.



**G13000R Digital Audio Router
P139-HD Installation and Operation Manual Supplement**

Section 2.0 Installation

2.1 Accessories Required but Not Supplied

Installation kits G13000M15-IKC (x1) and G13000M50-IKC (x2) are required to complete the installation. These kits consist of the following:

G13000M15-IKC

Qty	Description	Manufacturer	Mfr Part #	AEM Part #
1	D-Sub Socket Crimp 15P	MIL Spec	M24308/2-2F	120-21-008
1	Backshell DB15	Conec	165X11619XE	120-28-015
1	D-Sub Cable Clamp 3-12mm	Conec	160X11189XE	120-30-015

G13000M50-IKC

Qty	Description	Manufacturer	Mfr Part #	AEM Part #
1	D-Sub Plug Crimp 50P	MIL Spec	M24308/4-5F	120-11-005
1	D-Sub Socket Crimp 50P	MIL Spec	M24308/2-5F	20-21-M50
2	Backshell DB50	Conec	165X11649XE	120-28-011
2	D-Sub Cable Clamp 5-14mm	Conec	160X11199XE	120-30-004

For installation information and drawings, see the P139-HD Installation Manual. The drawings specific to the G13000R are listed below and can be found at the end of this supplement.

2.2 Installation Drawings

DOCUMENT Part No.	REV.	DESCRIPTION	TYPE	SERIAL NO.
G13000R-403-0	1.01	Router	Interconnect	118891 and up
G13000R-405-0	1.00	Router	Connector Map	118891 and up
G13000R-922-0	1.20	Audio Router	Mechanical Installation	118891 and up



G13000R Digital Audio Router P139-HD Installation and Operation Manual Supplement

Section 3.0 Operation

For operation information, see the P139-HD Digital Audio System User Manual with the following exceptions/additions:

- a) Operational references to G13000 can also include G13000R.

3.1 General

3.1.1 Speaker Output

The G13000R 25W Speaker Output replaces the existing TX4 HI/LO output from XCVR4 on the PILOT radio stack (Connector J1 pins 13, 14).

The speaker output requires definition for operation in the router configuration.

3.1.2 Troubleshooting

Problem	Solution(s)
No Output on Speaker	<ul style="list-style-type: none">• Confirm G13000R and P139-HD system is powered on and otherwise functioning normally• Ensure correct harness wiring between the speaker and J1 pins 13 & 14• Check that the signed system configuration sheet lists included outputs to the speaker• Contact AEM Technical Support to confirm that the memory card configuration includes the outputs to the speaker
Low Output on Speaker	<ul style="list-style-type: none">• Ensure that the resultant effective impedance is 8 Ohms connected to the Speaker Output, verify proper series and/or series parallel speaker wiring• Verify sufficient wire gauge is used in the installation

Supplement Ends After Attached Documents

G13000R INSTALLATION NOTES:

REVISIONS			
REV	DESCRIPTION	DATE	BY
1.01	ECO1256 - SHEET 8: G13000R J3 PINS 35/36 CORRECTED	13-JAN-2026	AJV

NOTES:

1. UNLESS OTHERWISE NOTED: ALL WIRES ARE 22 AWG; ALL SHIELDED WIRE IS MIL-DTL-27500; ALL UNSHIELDED WIRE IS MIL-W-22759/16.
2. ALL GROUNDING AND BONDING WILL BE I/A/W AC 43.13-1B, CHAPTER 1, SECTION 15.
3. GROUND THE SHIELD RETURN TO THE METAL CONNECTOR BACKSHELL IF USED, OR OTHERWISE TO THE METAL CONNECTOR HOUSING.
4. SPARE KEY LINE FUNCTION AND CONNECTIONS ARE INSTALLER DEFINED AND DEPEND ON THE SPECIFIC SYSTEM CONFIGURATION.
5. D50M CONNECTOR ASSEMBLY CONSISTS OF: CONNECTOR M24308/4-5F; CINCH BACKSHELL DD-24661-34; 2EA. CINCH SCREWLOCKS D20420-42. ALTERNATE BACKSHELL: CONEC 165X10179X.
6. D50F CONNECTOR ASSEMBLY CONSISTS OF: CONNECTOR M24308/2-5F; CINCH BACKSHELL DD-24661-34; 2EA. CINCH SCREWLOCKS D20420-42. ALTERNATE BACKSHELL: CONEC 165X10179X.
7. WHEN COM1DIR (P5, PIN 10) IS NOT GROUNDED, THE PILOT HEADSET IS IN EMERGENCY MODE AND THE FOLLOWING LINES ARE DIVERTED:
 - HEADSET 1 CONNECTS DIRECTLY TO RX1, RX11 (UNSWITCHED ALERT TONES) AND THE EMERGENCY INTERCOM.
 - MIC 1 CONNECTS DIRECTLY TO TX 1 AND THE EMERGENCY INTERCOM.
 - XMIT KEY 1 AND PLT COM1 KEY CONNECT TO TX KEY 1.
 - ICS KEY 1 KEYS THE EMERGENCY INTERCOM, IF AT LEAST ONE POWER INPUT CIRCUIT BREAKER TO THE G13000 AUDIO ROUTER HAS POWER.
 - TX11 (CVR) TRANSMITS HEADSET1, MIC1 AND EMERGENCY INTERCOM IF AT LEAST ONE POWER INPUT CIRCUIT BREAKER TO THE G13000 AUDIO ROUTER HAS POWER.
8. WHEN COM2DIR (P5, PIN 11) IS NOT GROUNDED, THE COPILOT HEADSET IS IN EMERGENCY MODE AND THE FOLLOWING LINES ARE DIVERTED:
 - HEADSET 2 CONNECTS DIRECTLY TO RX2, RX20 (UNSWITCHED ALERT TONES) AND THE EMERGENCY INTERCOM.
 - MIC 2 CONNECTS DIRECTLY TO TX 2, AND THE EMERGENCY INTERCOM.
 - XMIT KEY 2 AND CPLT COM2 KEY CONNECT TO TX KEY 2.
 - ICS KEY 2 KEYS THE EMERGENCY INTERCOM, IF AT LEAST ONE POWER INPUT CIRCUIT BREAKER TO THE G13000 AUDIO ROUTER HAS POWER.
 - TX20 (CVR) TRANSMITS HEADSET2, MIC2 AND EMERGENCY INTERCOM IF AT LEAST ONE POWER INPUT CIRCUIT BREAKER TO THE G13000 AUDIO ROUTER HAS POWER.
8. D15F CONNECTOR PREFERRED ASSEMBLY CONSISTS OF: CONNECTOR M24308/2-2F; CINCH BACKSHELL DA-24658-31; 2EA. CINCH SCREWLOCKS D20419-46. ALTERNATE BACKSHELL: CONEC P/N: 165X10149X. SPLICES ON 20 AWG WIRE SHALL ALSO BE 20 AWG, LENGTH 3 INCHES MAXIMUM. ALTERNATE ASSEMBLY CONSISTS OF: KOBICONN SOLDER-CUP CONNECTOR 156-1315T-E AND CINCH BACKSHELL DA-24658-31; 2EA. CINCH SCREWLOCKS D20419-46. ALTERNATE BACKSHELL: CONEC P/N: 165X10149X. CONDUCTORS SHOWN WITH SPLICES MAY BE IMPLEMENTED BY SOLDERING THE SUPPLY WIRE TO BOTH PINS AFTER SOLDERING AND INSULATING THE ADJACENT CONNECTIONS.

9. D9M CONNECTOR ASSEMBLY CONSISTS OF: CONNECTOR M24308/4-1F; CINCH BACKSHELL DE-24657-30; 2EA. CINCH SCREWLOCKS D20419-46. ALTERNATE BACKSHELL: CONEC 165X10139X.
10. THE COM1 DIR PIN MUST BE WIRED TO AN APPROPRIATE SWITCH TO CONTROL EMERGENCY MODE FOR THE PILOT HEADSET. EMERGENCY MODE IS MANDATORY WHEN THE G13000 AUDIO ROUTER IS USED AS THE PRIMARY AUDIO SYSTEM. SEE NOTES ON SHEET 8.
11. FOR EC135 CONNECT ALERT TONE PORTS TO TB9 OF FACTORY WIRING. SEE EUROCOPTER MAINT. MANUAL WDM FOR DETAIL. FOR EC145 CONNECT ALERT TONE PORTS TO TB55028 OF FACTORY WIRING. SEE EUROCOPTER MAINT. MANUAL WDM FOR DETAIL. FOR BELL 204, 205, 214 AND 412 CONNECT ALERT TONE PORTS TO 8Z1P3. SEE BELL MAINT. MANUAL BHT-XX-MM FOR DETAIL.
12. SHIELDING: FOR SHIELDED WIRE, THE SHIELD MUST BE CONNECTED TO AIRFRAME GROUND OR CONNECTOR GROUND AS FOLLOWS:
 - FOR WIRE CARRYING AUDIO SIGNALS, THE SHIELD MUST BE GROUNDED AT ONE END ONLY. GROUNDING BOTH ENDS MAY LEAD TO AUDIO NOISE.
 - AUDIO SHIELD GROUND CONNECTIONS SHOULD BE MADE AT THE G13000 CONNECTORS BUT MAY BE MADE AT THE OTHER END AT THE INSTALLERS DISCRETION.
 - FOR ALL OTHER SHIELDED WIRE, E.G. GNET AND POWER, THE SHIELD MUST BE GROUNDED AT BOTH ENDS.
13. BUS CONNECTIONS: BREAKERS SHOULD BE CONNECTED TO TWO SEPARATE BUSES FOR REDUNDANCY. CONSULT INSTALLATION INSTRUCTIONS TO DETERMINE APPROPRIATE BUS ASSIGNMENTS.
14. HEADSET LO IS NOT A POWER GROUND AND MUST NOT BE USED AS A GROUND FOR POWERED DEVICES. MIC LO MAY BE USED AS A GROUND FOR LOW-POWERED DEVICES OR USE AN EXTERNAL GROUND CONNECTION.
15. RADIO PORTS ARE DIFFERENTIAL INPUTS AND OUTPUTS. RX LO AND TX LO MUST BE GROUNDED IF THE CONNECTED DEVICE IS SINGLE-ENDED.
16. EQUIVALENT SERIES PARALLEL SPEAKERS MAY BE USED.
17. BLUETOOTH AUDIO CONNECTIONS ONLY PRESENT ON BLUETOOTH ENABLED CONTROL HEADS. RECOMMEND ONLY ONE BLUETOOTH ENABLED CONTROL HEAD PER SYSTEM.
18. THE BLUETOOTH TRANSCEIVER LOCATED WITHIN THE G1311XR CONTROL HEAD MAY BE ROUTED TO ANY AVAILABLE RADIO PORT ON THE AUDIO ROUTER. ACTIVATION AND ROUTING OF THE BLUETOOTH AUDIO IS CONTROLLED BY THE CONFIGURATION INSTALLED WITHIN THE AUDIO ROUTER.

DEFINITIONS:

- N/C: NO CONNECTION. THE PIN IS NOT CONNECTED TO ANYTHING INTERNALLY, AND THEREFORE SHALL HAVE NO CONNECTION EXTERNALLY.
- N/C SPARE: NO CONNECTION INTERNALLY, BUT A SPARE WIRE SHALL BE INSTALLED IN THE WIRE HARNESS.
- RESERVED: MAY BE CONNECTED AND USED IN THE FUTURE. THE CIRCUITRY MAY BE PRESENT OR ADDED TO ACTIVATE THE FUNCTION. THE PIN MAY BE USED FOR TEST PURPOSES. THERE IS NO EXTERNAL CONNECTION.
- RESERVED, SPARE: (RSV, SP) RESERVED, BUT INSTRUCTIONS SHALL BE FOLLOWED TO ACTIVATE THE CIRCUITRY. A SPARE WIRE SHALL BE INSTALLED IN THE WIRE HARNESS.

NAME		DATE	UNLESS OTHERWISE SPECIFIED:		 ANDDYNE ELECTRONICS MANUFACTURING CORP. KELOWNA BC CANADA (250)-763-1088 WWW.AEM-CORP.COM
DRAWN	DMF/LAC	07-Nov-2024	DIMENSIONS ARE IN INCHES [MM]		
CHECKED			TOLERANCES:		
APPROVED			FRACTIONAL ±0.0625" ANGULAR ±0.5° TWO DECIMAL PLACE ±0.010" THREE DECIMAL PLACE ±0.005"		
CONFIDENTIAL AND PROPRIETARY THE INFORMATION CONTAINED IN THIS DRAWING IS THE SOLE PROPERTY OF ANDDYNE ELECTRONICS MANUFACTURING. ANY REPRODUCTION IN PART OR AS A WHOLE WITHOUT THE WRITTEN PERMISSION OF ANDDYNE ELECTRONICS MANUFACTURING IS PROHIBITED.			MATERIAL:		TITLE: <h3 style="text-align: center;">ROUTER, NOTES INTERCONNECT</h3>
			N/A		
			FINISH:		
			N/A		PAPER SIZE: B CAGE CODE: L9015 PART NO.: G13000R REVISION: 1.01
					SCALE: 1:1 DO NOT SCALE DRAWING DRAWING No.: 403-0 SHEET: 1 of 8

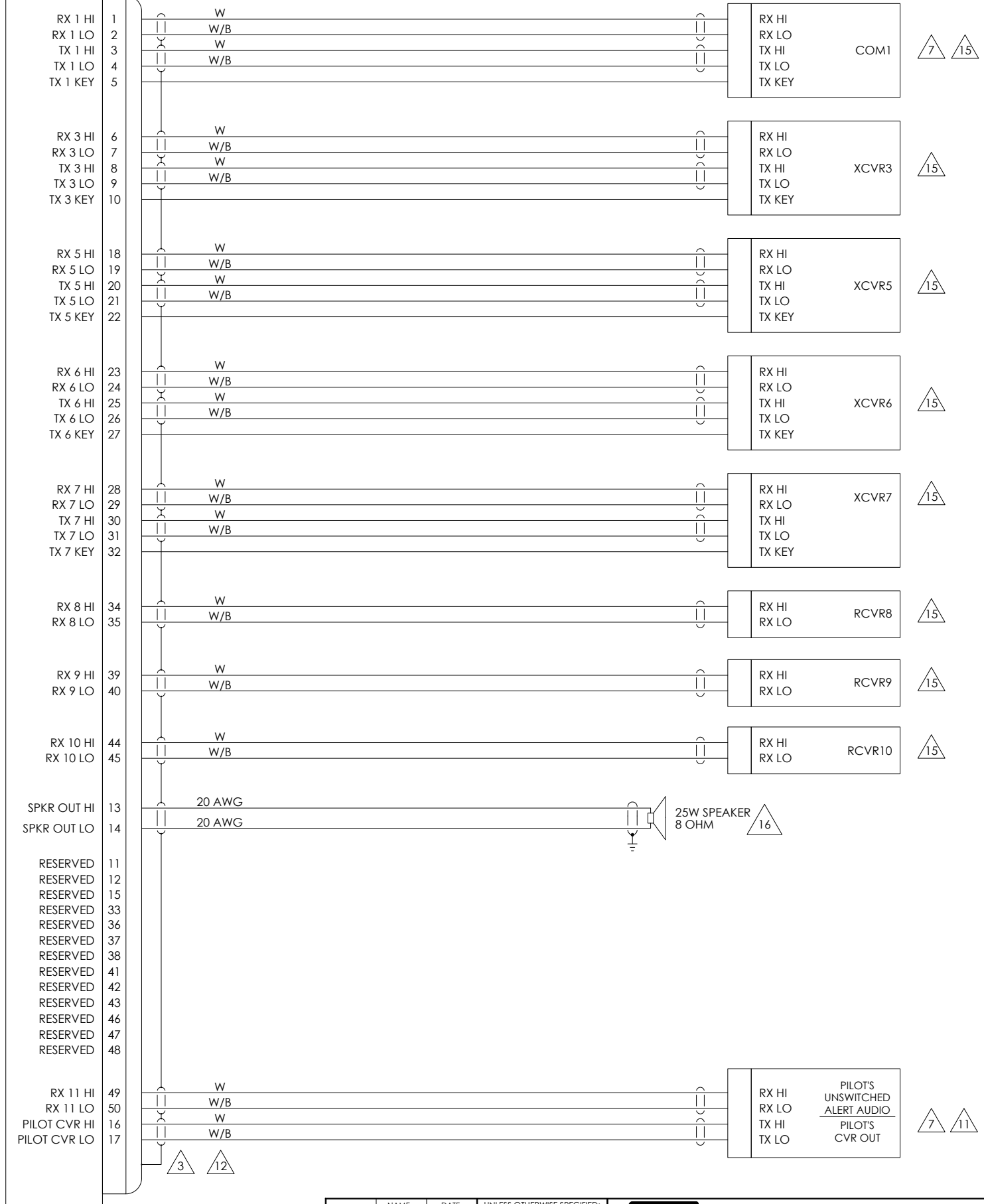

NAME	DATE	UNLESS OTHERWISE SPECIFIED:
DRAWN	DMF/LAC 07-Nov-2024	DIMENSIONS ARE IN INCHES [MM]
CHECKED		TOLERANCES:
APPROVED		FRACTIONAL ±0.0625"
		ANGULAR ±0.5°
		TWO DECIMAL PLACE ±0.010"
		THREE DECIMAL PLACE ±0.005"
CONFIDENTIAL AND PROPRIETARY THE INFORMATION CONTAINED IN THIS DRAWING IS THE SOLE PROPERTY OF ANODYNE ELECTRONICS MANUFACTURING. ANY REPRODUCTION IN PART OR AS A WHOLE WITHOUT THE WRITTEN PERMISSION OF ANODYNE ELECTRONICS MANUFACTURING IS PROHIBITED.		MATERIAL: N/A
		FINISH: N/A



KELOWNA BC CANADA
(250)-763-1088
WWW.AEM-CORP.COM

TITLE: ROUTER INTERCONNECT			
PAPER SIZE: B	CAGE CODE: L9015	PART No.:	REVISION: 1.01
SCALE: 1:1		DO NOT SCALE DRAWING	DRAWING No.: 403-0
			SHEET: 2 of 8

J2

P2
50 PIN FEMALE DSUB
MATING CONNECTOR

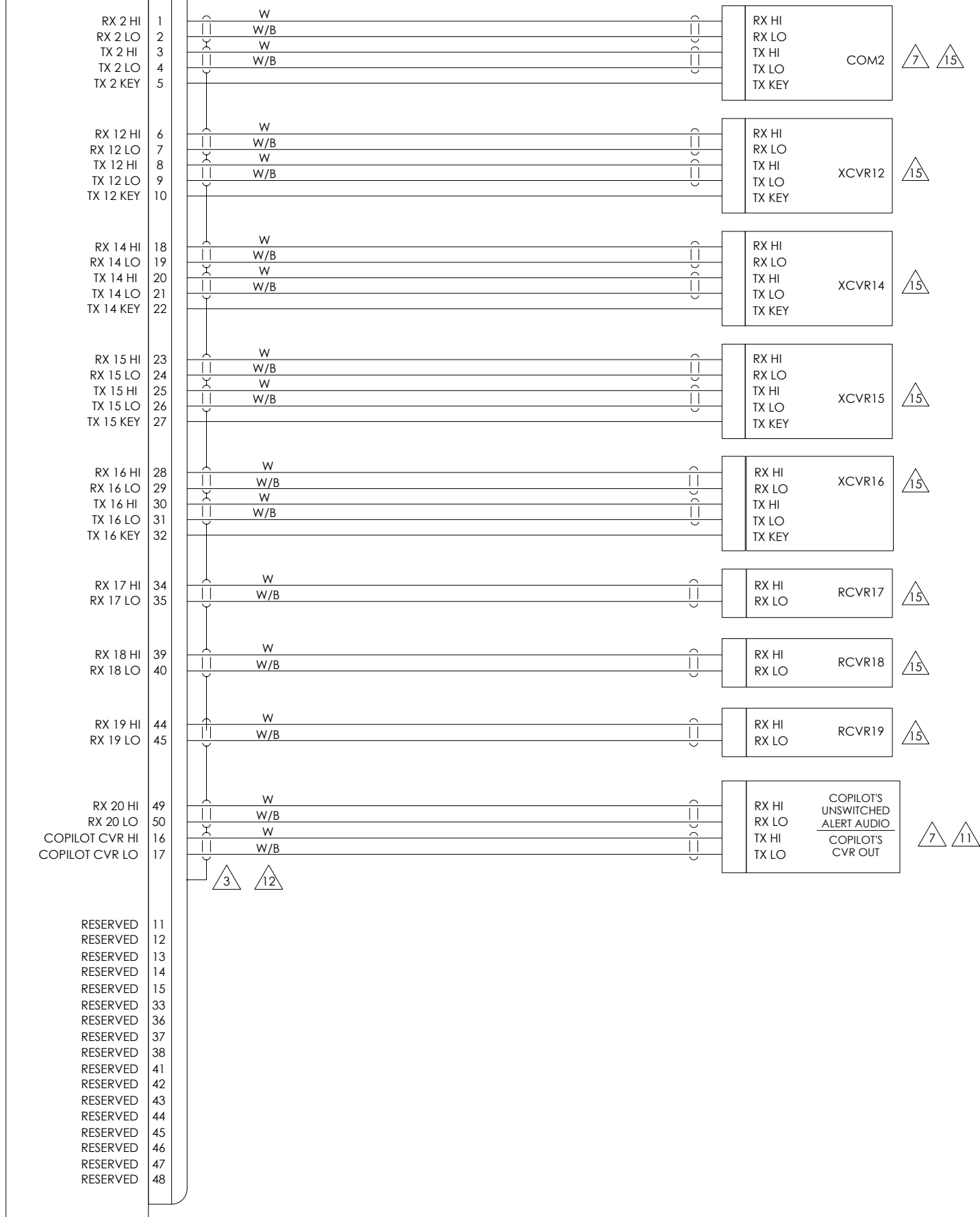

NAME	DATE	UNLESS OTHERWISE SPECIFIED:
DRAWN	DMF/LAC 07-Nov-2024	DIMENSIONS ARE IN INCHES [MM]
CHECKED		TOLERANCES:
APPROVED		FRACTIONAL: ±0.0625"
		ANGULAR: ±0.5°
		TWO DECIMAL PLACE: ±0.010"
		THREE DECIMAL PLACE: ±0.005"
CONFIDENTIAL AND PROPRIETARY THE INFORMATION CONTAINED IN THIS DRAWING IS THE SOLE PROPERTY OF ANODYNE ELECTRONICS MANUFACTURING. ANY REPRODUCTION IN PART OR AS A WHOLE WITHOUT THE WRITTEN PERMISSION OF ANODYNE ELECTRONICS MANUFACTURING IS PROHIBITED.		MATERIAL: N/A
		FINISH: N/A



ANODYNE ELECTRONICS MANUFACTURING CORP.

KELOWNA BC CANADA
(250)-763-1088
WWW.AEM-CORP.COM

TITLE: ROUTER INTERCONNECT			
PAPER SIZE: B	CAGE CODE: L9015	PART No.:	REVISION: 1.01
SCALE: 1:1		DO NOT SCALE DRAWING	DRAWING No.: 403-0
			SHEET: 3 of 8

G13000R

J3

P3
50 PIN MALE DSUB
MATING CONNECTOR

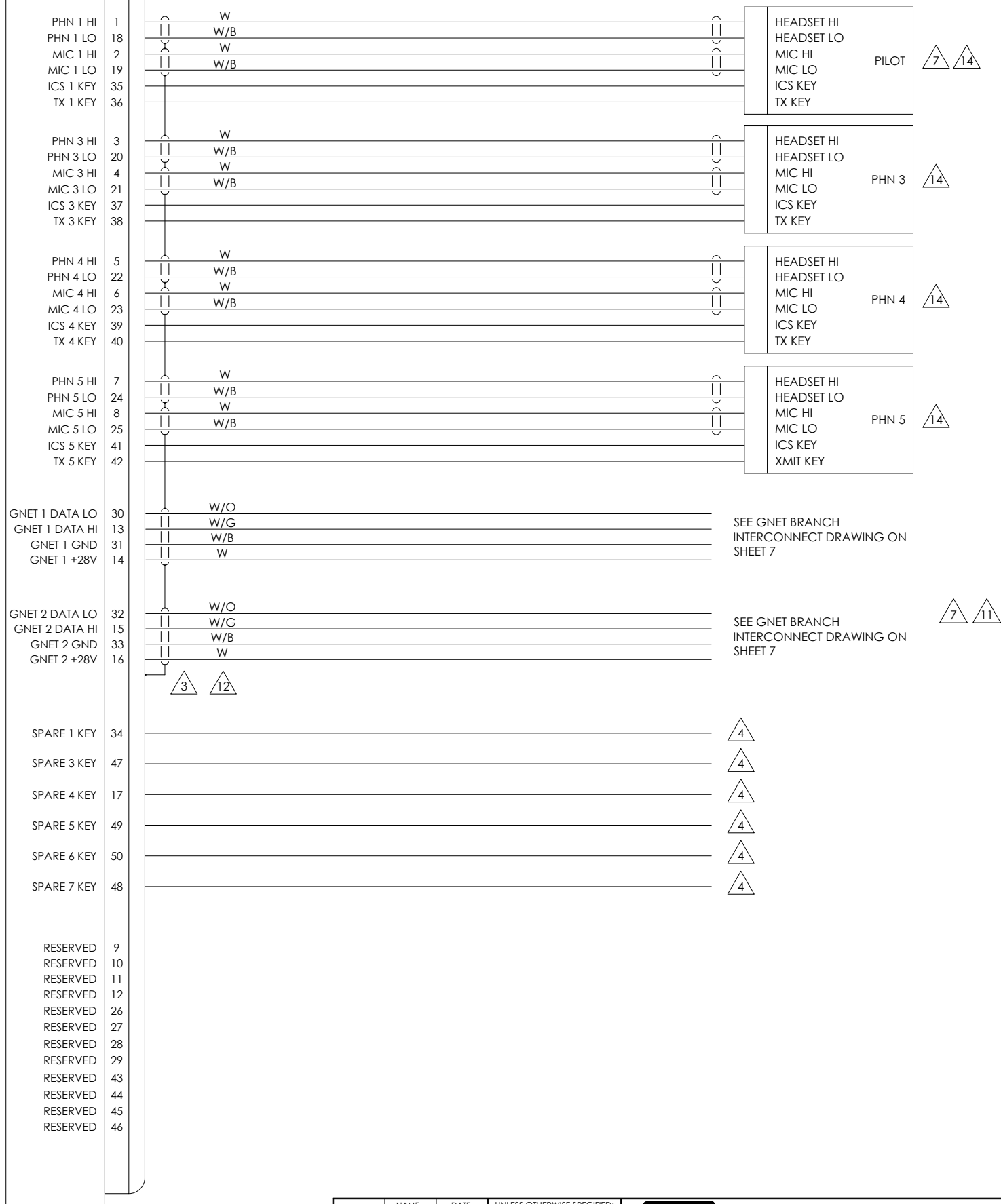

NAME	DATE	UNLESS OTHERWISE SPECIFIED:	AEM ANODYNE ELECTRONICS MANUFACTURING CORP.		KELOWNA BC CANADA (250)-763-1088 WWW.AEM-CORP.COM
DRAWN	DMF/LAC 07-Nov-2024	DIMENSIONS ARE IN INCHES [MM]	ROUTER INTERCONNECT PAPER SIZE: B CAGE CODE: L9015 PART No.: G13000R REVISION: 1.01 SCALE: 1:1 DO NOT SCALE DRAWING DRAWING No.: 403-0 SHEET: 4 of 8		
CHECKED		TOLERANCES:			
APPROVED		FRACTIONAL ±0.0625"			
		ANGULAR ±0.5°			
		TWO DECIMAL PLACE ±0.010"			
		THREE DECIMAL PLACE ±0.005"			
CONFIDENTIAL AND PROPRIETARY THE INFORMATION CONTAINED IN THIS DRAWING IS THE SOLE PROPERTY OF ANODYNE ELECTRONICS MANUFACTURING. ANY REPRODUCTION IN PART OR AS A WHOLE WITHOUT THE WRITTEN PERMISSION OF ANODYNE ELECTRONICS MANUFACTURING IS PROHIBITED.		MATERIAL:			
		N/A			
		FINISH:			
		N/A			
		-			

J4

P4
50 PIN MALE DSUB
MATING CONNECTOR



PHN 2 HI
PHN 2 LO
MIC 2 HI
MIC 2 LO
ICS 2 KEY
TX 2 KEY

1
18
2
19
35
36

W
W/B
W
W/B

HEADSET HI
HEADSET LO
MIC HI
MIC LO
ICS KEY
TX KEY

COPILOT



PHN 8 HI
PHN 8 LO
MIC 8 HI
MIC 8 LO
ICS 8 KEY
TX 8 KEY

3
20
4
21
37
38

W
W/B
W
W/B

HEADSET HI
HEADSET LO
MIC HI
MIC LO
ICS KEY
TX KEY

PHN 8



PHN 9 HI
PHN 9 LO
MIC 9 HI
MIC 9 LO
ICS 9 KEY
TX 9 KEY

5
22
6
23
39
40

W
W/B
W
W/B

HEADSET HI
HEADSET LO
MIC HI
MIC LO
ICS KEY
TX KEY

PHN 9



PHN 10 HI
PHN 10 LO
MIC 10 HI
MIC 10 LO
ICS 10 KEY
TX 10 KEY

7
24
8
25
41
42

W
W/B
W
W/B

HEADSET HI
HEADSET LO
MIC HI
MIC LO
ICS KEY
TX KEY

PHN 10



GNET 3 DATA LO
GNET 3 DATA HI
GNET 3 GND
GNET 3 +28V

30
13
31
14

W/O
W/G
W/B
W

SEE GNET BRANCH
INTERCONNECT DRAWING ON
SHEET 7

GNET 4 DATA LO
GNET 4 DATA HI
GNET 4 GND
GNET 4 +28V

32
15
33
16

W/O
W/G
W/B
W

SEE GNET BRANCH
INTERCONNECT DRAWING ON
SHEET 7



SPARE 2 KEY
SPARE 8 KEY
SPARE 9 KEY
SPARE 10 KEY
SPARE 11 KEY
SPARE 12 KEY

34
47
17
49
50
48

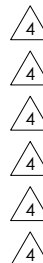

RESERVED
RESERVED
RESERVED
RESERVED
RESERVED
RESERVED
RESERVED
RESERVED
RESERVED
RESERVED
RESERVED

9
10
11
12
26
27
28
29
43
44
45
46

NAME	DATE	UNLESS OTHERWISE SPECIFIED:
DRAWN	DMF/LAC 07-Nov-2024	DIMENSIONS ARE IN INCHES [MM]
CHECKED		TOLERANCES:
APPROVED		FRACTIONAL ±0.0625"
<p>CONFIDENTIAL AND PROPRIETARY THE INFORMATION CONTAINED IN THIS DRAWING IS THE SOLE PROPERTY OF ANODYNE ELECTRONICS MANUFACTURING. ANY REPRODUCTION IN PART OR AS A WHOLE WITHOUT THE WRITTEN PERMISSION OF ANODYNE ELECTRONICS MANUFACTURING IS PROHIBITED.</p>		ANGULAR ±0.5°
		TWO DECIMAL PLACE ±0.010"
		THREE DECIMAL PLACE ±0.005"
MATERIAL:		N/A
FINISH:		N/A





ANODYNE ELECTRONICS MANUFACTURING CORP.

KELOWNA BC CANADA
(250)-763-1088
WWW.AEM-CORP.COM

TITLE: ROUTER INTERCONNECT			
PAPER SIZE: B	CAGE CODE: L9015	PART No.:	REVISION: 1.01
SCALE: 1:1		DO NOT SCALE DRAWING	DRAWING No.: 403-0
			SHEET: 5 of 8

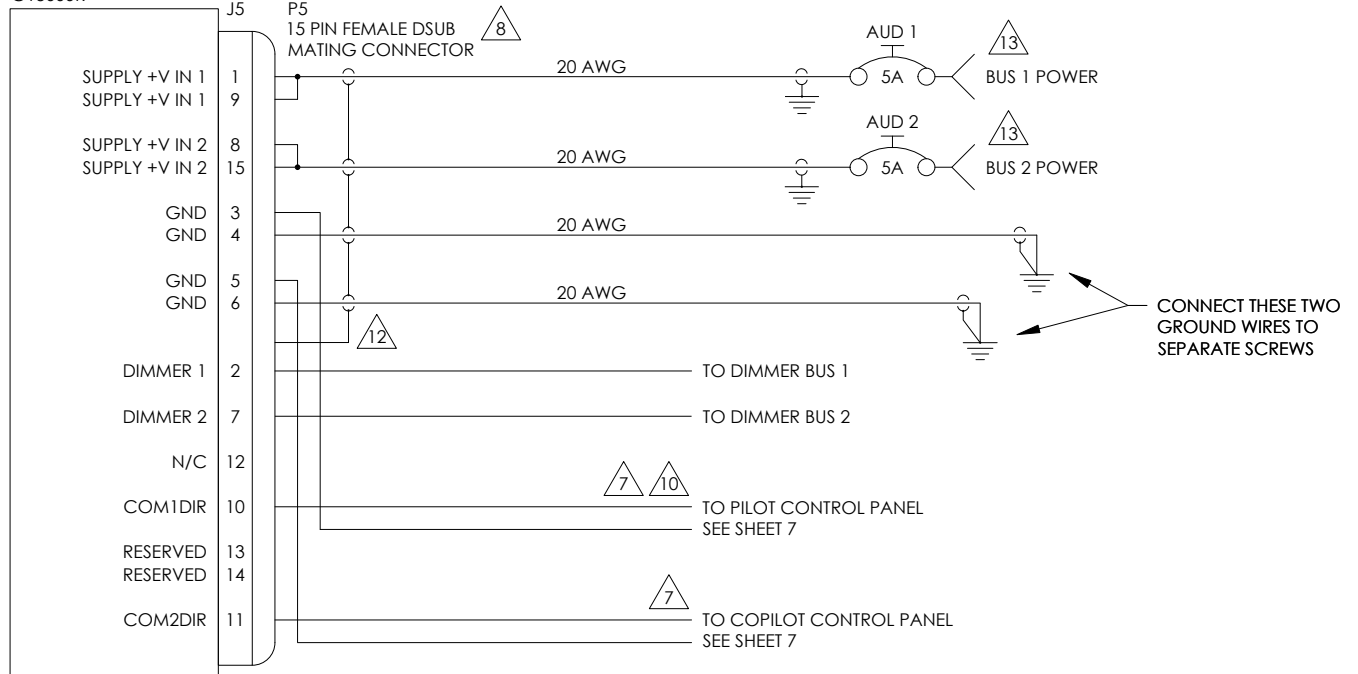
G13000R



NAME		DATE	UNLESS OTHERWISE SPECIFIED:				KELOWNA BC CANADA (250)-763-1088 WWW.AEM-CORP.COM	
DRAWN	DMF/LAC	07-Nov-2024	DIMENSIONS ARE IN INCHES [MM]		PAPER SIZE: B		CAGE CODE: L9015	
CHECKED			TOLERANCES:		PART No.:		REVISION: 1.01	
APPROVED			FRACTIONAL: ±0.0625"		G13000R		SCALE: 1:1	
CONFIDENTIAL AND PROPRIETARY THE INFORMATION CONTAINED IN THIS DRAWING IS THE SOLE PROPERTY OF ANODYNE ELECTRONICS MANUFACTURING. ANY REPRODUCTION IN PART OR AS A WHOLE WITHOUT THE WRITTEN PERMISSION OF ANODYNE ELECTRONICS MANUFACTURING IS PROHIBITED.			MATERIAL:		DO NOT SCALE DRAWING		DRAWING No.: 403-0	
			N/A		SCALE: 1:1		SHEET: 6 of 8	
			FINISH:		-			

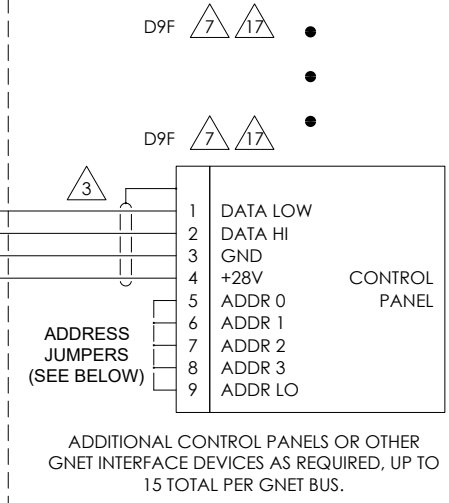
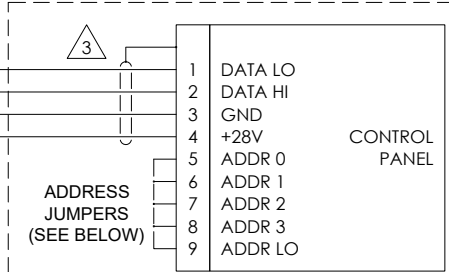
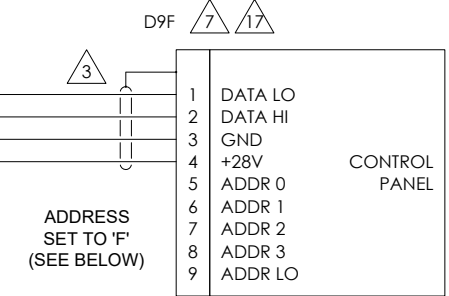
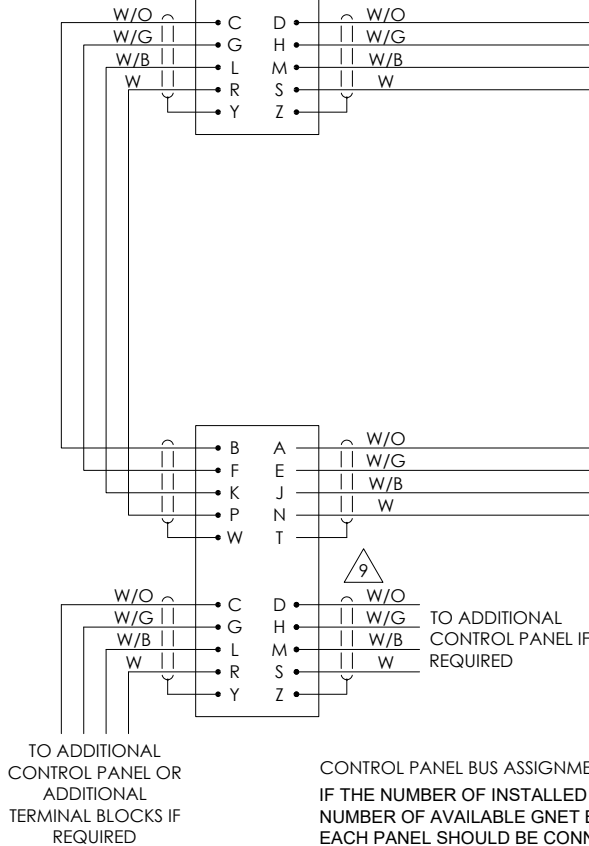
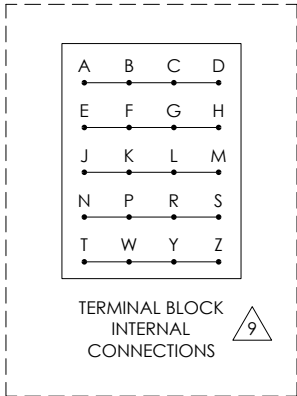
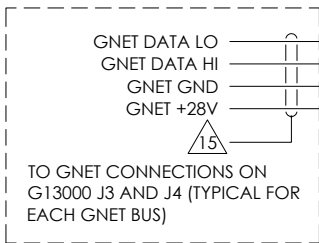

CONTROL PANEL BUS ASSIGNMENT:
 IF THE NUMBER OF INSTALLED CONTROL PANELS IS EQUAL TO OR LESS THAN THE NUMBER OF AVAILABLE GNET BUSES (4 FOR DUAL-BOARD, 2 FOR SINGLE-BOARD) THEN EACH PANEL SHOULD BE CONNECTED TO A SEPARATE GNET BUS AND TERMINAL BLOCKS ARE NOT REQUIRED.

THE PILOT'S PRIMARY CONTROL PANEL SHOULD BE THE FIRST DEVICE ON GNET BUS 1. THE COPILOT'S PRIMARY CONTROL PANEL SHOULD BE THE FIRST DEVICE ON GNET 3 IN A DUAL-BOARD SYSTEM AND THE FIRST DEVICE ON GNET 2 ON A SINGLE-BOARD SYSTEM.

ADDITIONAL CONTROL PANELS SHOULD BE EVENLY DISTRIBUTED AMONG AVAILABLE GNET BUSES.

GNET ADDRESS JUMPERS:
 FOR EVERY CONTROL PANEL OR OTHER PERIPHERAL DEVICE CONNECTED TO A PARTICULAR GNET BUS, A UNIQUE DEVICE ADDRESS FROM "1" TO "9" OR "A" TO "F" MUST BE WIRED INTO THE CONNECTOR. THE ADDRESS FOR EACH DEVICE ON EACH GNET BUS IS DEFINED IN THE SYSTEM CONFIGURATION SOFTWARE FOR THE SPECIFIC INSTALLATION.
 USING 24 AWG WIRE 1.5" LONG FOR EACH JUMPER, CONNECT THE FOLLOWING PINS TOGETHER FOR GNET ADDRESSING FOR EACH CONNECTOR, AS SPECIFIED IN THE SYSTEM CONFIGURATION REQUIREMENTS. MAKE NO CONNECTIONS TO UNLISTED PINS.
 THE FIRST CONTROL PANEL ON ANY GIVEN GNET BUS SHOULD BE SET AS ADDRESS "F" WITH NO JUMPERS. ADDITIONAL PANELS ON THE SAME BUS SHOULD BE GIVEN ADDRESSES IN DESCENDING ORDER: "E", "D", "C" ETC.

"1" = 6-7-8-9	"5" = 6-8-9	"9" = 6-7-9	"D" = 6-9
"2" = 5-7-8-9	"6" = 5-8-9	"A" = 5-7-9	"E" = 5-9
"3" = 7-8-9	"7" = 8-9	"B" = 7-9	"F" = NONE
"4" = 5-6-8-9	"8" = 5-6-7-9	"C" = 5-6-9	

GNET EXTERNAL POWER:
 IF THE AUDIO SYSTEM HAS MORE THAN 6 CONTROL PANELS AN EXTERNAL POWER SOURCE FOR THE ADDITIONAL PANELS MUST BE PROVIDED. UP TO 12 ADDITIONAL CONTROL PANELS MAY BE POWERED FROM EACH EXTERNAL 5A BREAKER. CONTROL PANELS POWERED BY AN EXTERNAL BREAKER SHOULD NOT BE CONNECTED TO ROUTER GNET POWER.

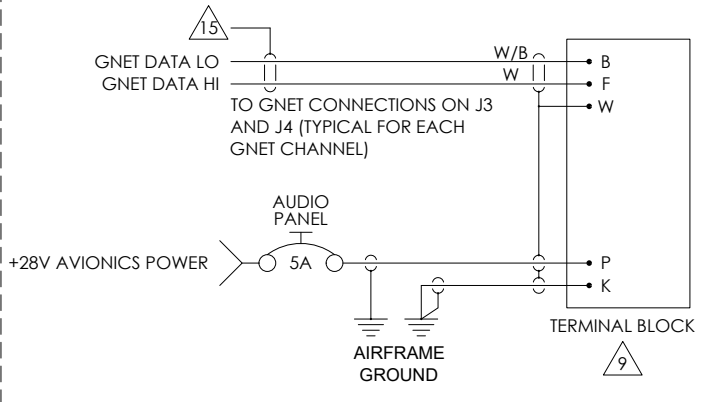

NAME	DATE	UNLESS OTHERWISE SPECIFIED:
DRAWN DMF/LAC	07-Nov-2024	DIMENSIONS ARE IN INCHES (MM)
CHECKED		TOLERANCES:
APPROVED		FRACTIONAL ±0.0625"
		ANGULAR ±0.5°
		TWO DECIMAL PLACE ±0.010"
		THREE DECIMAL PLACE ±0.005"
CONFIDENTIAL AND PROPRIETARY THE INFORMATION CONTAINED IN THIS DRAWING IS THE SOLE PROPERTY OF ANODYNE ELECTRONICS MANUFACTURING. ANY REPRODUCTION IN PART OR AS A WHOLE WITHOUT THE WRITTEN PERMISSION OF ANODYNE ELECTRONICS MANUFACTURING IS PROHIBITED.		MATERIAL: N/A
		FINISH: N/A

AEM ANODYNE ELECTRONICS MANUFACTURING CORP.

KELOWNA BC CANADA (250)-763-1088 WWW.AEM-CORP.COM

TITLE: **ROUTER INTERCONNECT**

PAPER SIZE: B	CAGE CODE: L9015	PART NO.: G13000R	REVISION: 1.01
SCALE: 1:1	DO NOT SCALE DRAWING	DRAWING No.: 403-0	SHEET: 7 of 8

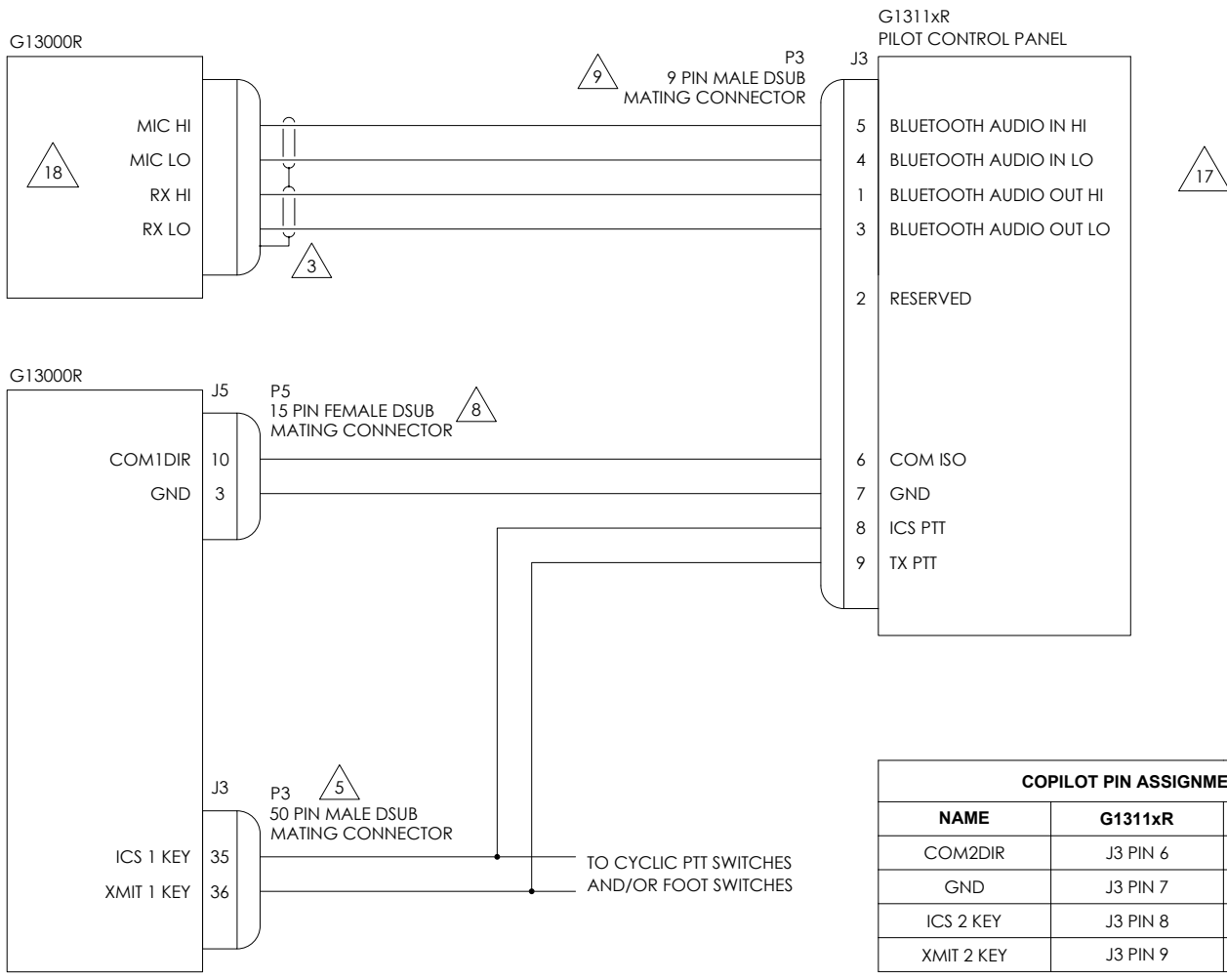

COPILOT PIN ASSIGNMENT		
NAME	G1311xR	G13000R
COM2DIR	J3 PIN 6	J5 PIN 11
GND	J3 PIN 7	J5 PIN 5
ICS 2 KEY	J3 PIN 8	J4 PIN 35
XMIT 2 KEY	J3 PIN 9	J4 PIN 36

ON A SINGLE-BOARD SYSTEM: G13000(S), THERE IS NO COPILOT EMERGENCY MODE, AND THE COM2DIR PIN IS NOT CONNECTED.

NAME	DATE	UNLESS OTHERWISE SPECIFIED:		KELOWNA BC CANADA (250)-763-1088 WWW.AEM-CORP.COM
DRAWN	DMF/LAC 07-Nov-2024	DIMENSIONS ARE IN INCHES [MM]		
CHECKED		FRACTIONAL _____ ±0.0625"	TITLE: ROUTER INTERCONNECT	
APPROVED		ANGULAR _____ ±0.5°		
CONFIDENTIAL AND PROPRIETARY THE INFORMATION CONTAINED IN THIS DRAWING IS THE SOLE PROPERTY OF ANODYNE ELECTRONICS MANUFACTURING. ANY REPRODUCTION IN PART OR AS A WHOLE WITHOUT THE WRITTEN PERMISSION OF ANODYNE ELECTRONICS MANUFACTURING IS PROHIBITED.		MATERIAL:	PAPER SIZE: CAGE CODE PART No.: B L9015 G13000R	
		FINISH:		
			SCALE: 1:1 DO NOT SCALE DRAWING DRAWING No.: 403-0 SHEET: 8 of 8	

P1

50 PIN FEMALE DSUB
MATING CONNECTOR

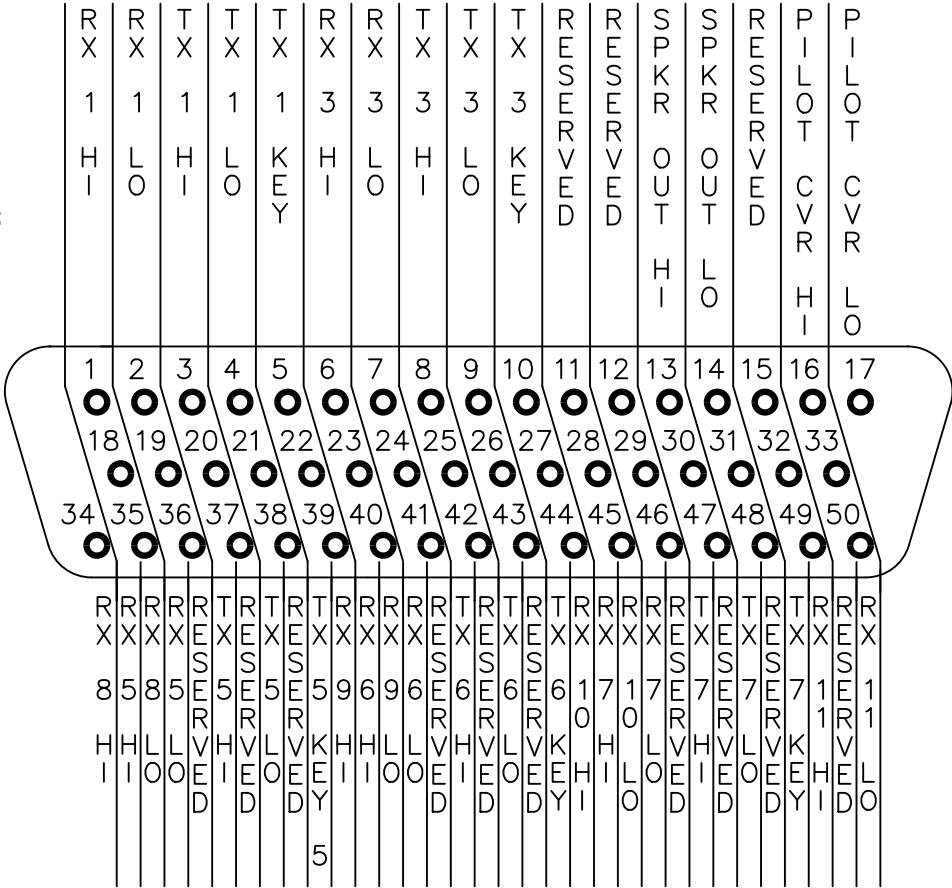

VIEW IS FROM REAR OF AIRFRAME CONNECTOR

NAME		DATE		UNLESS OTHERWISE SPECIFIED:				KELOWNA BC CANADA (250)-763-1088 WWW.AEM-CORP.COM					
DRAWN	DMF/LAC	07-Nov-2024		DIMENSIONS ARE IN INCHES [MM]									
CHECKED				TOLERANCES:		TITLE: ROUTER CONNECTOR MAP							
APPROVED				FRACTIONAL _____ ±0.0625"									
				ANGULAR _____ ±0.5°									
CONFIDENTIAL AND PROPRIETARY THE INFORMATION CONTAINED IN THIS DRAWING IS THE SOLE PROPERTY OF ANODYNE ELECTRONICS MANUFACTURING. ANY REPRODUCTION IN PART OR AS A WHOLE WITHOUT THE WRITTEN PERMISSION OF ANODYNE ELECTRONICS MANUFACTURING IS PROHIBITED.				MATERIAL:		PAPER SIZE:		CAGE CODE		PART No.:		REVISION	
				FINISH:		A		A		L9015		G13000R	
				-		SCALE: 1:1		DO NOT SCALE DRAWING		DRAWING No.: 405-0		SHEET: 1 of 5	

P2

50 PIN FEMALE DSUB
MATING CONNECTOR

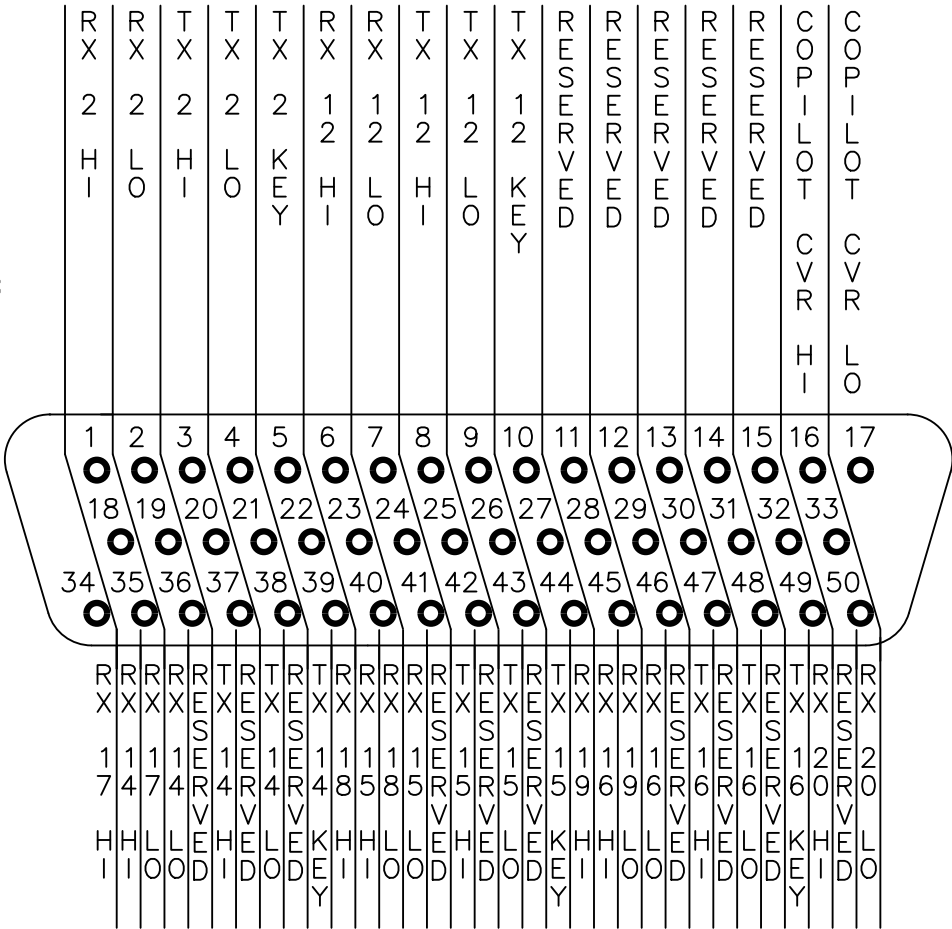

VIEW IS FROM REAR OF AIRFRAME CONNECTOR

NAME		DATE		UNLESS OTHERWISE SPECIFIED:		 ANODYNE ELECTRONICS MANUFACTURING CORP.		KELOWNA BC CANADA (250)-763-1088 WWW.AEM-CORP.COM					
DRAWN	DMF/LAC	07-Nov-2024		DIMENSIONS ARE IN INCHES [MM] TOLERANCES: FRACTIONAL _____ ±0.0625" ANGULAR _____ ±0.5° TWO DECIMAL PLACE _____ ±0.010" THREE DECIMAL PLACE _____ ±0.005"									
CHECKED						TITLE: ROUTER CONNECTOR MAP							
APPROVED													
CONFIDENTIAL AND PROPRIETARY THE INFORMATION CONTAINED IN THIS DRAWING IS THE SOLE PROPERTY OF ANODYNE ELECTRONICS MANUFACTURING. ANY REPRODUCTION IN PART OR AS A WHOLE WITHOUT THE WRITTEN PERMISSION OF ANODYNE ELECTRONICS MANUFACTURING IS PROHIBITED.				MATERIAL:		PAPER SIZE:		CAGE CODE		PART No.:		REVISION	
				FINISH:		A		A		L9015		G13000R	
				-		SCALE: 1:1		DO NOT SCALE DRAWING		DRAWING No.: 405-0		SHEET: 2 of 5	

P5

15 PIN FEMALE DSUB
MATING CONNECTOR

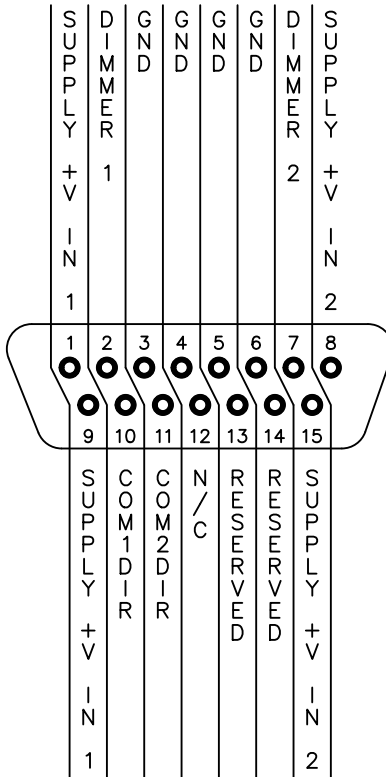

VIEW IS FROM REAR OF AIRFRAME CONNECTOR

	NAME	DATE	UNLESS OTHERWISE SPECIFIED:		 ANODYNE ELECTRONICS MANUFACTURING CORP.	KELOWNA BC CANADA (250)-763-1088 WWW.AEM-CORP.COM		
DRAWN	DMF/LAC	07-Nov-2024	DIMENSIONS ARE IN INCHES [MM] TOLERANCES: FRACTIONAL _____ ±0.0625" ANGULAR _____ ±0.5° TWO DECIMAL PLACE _____ ±0.010" THREE DECIMAL PLACE _____ ±0.005"			TITLE: ROUTER CONNECTOR MAP		
CHECKED			MATERIAL: NA		PAPER SIZE:	CAGE CODE	PART No.:	REVISION
APPROVED			FINISH: NA		A	L9015	G13000R	1.00
CONFIDENTIAL AND PROPRIETARY THE INFORMATION CONTAINED IN THIS DRAWING IS THE SOLE PROPERTY OF ANODYNE ELECTRONICS MANUFACTURING. ANY REPRODUCTION IN PART OR AS A WHOLE WITHOUT THE WRITTEN PERMISSION OF ANODYNE ELECTRONICS MANUFACTURING IS PROHIBITED.			-		SCALE: 1:1	DO NOT SCALE DRAWING	DRAWING No.: 405-0	SHEET: 5 of 5

REVISIONS			
REV.	DESCRIPTION	DATE	NAME
1.10	ECO1226 - CHASSIS AND COVER DESIGN CHANGES	20-Jan-2025	AJV
1.20	ECO1231 - CHASSIS AND COVER DESIGN CHANGES	19-Feb-2025	AJV

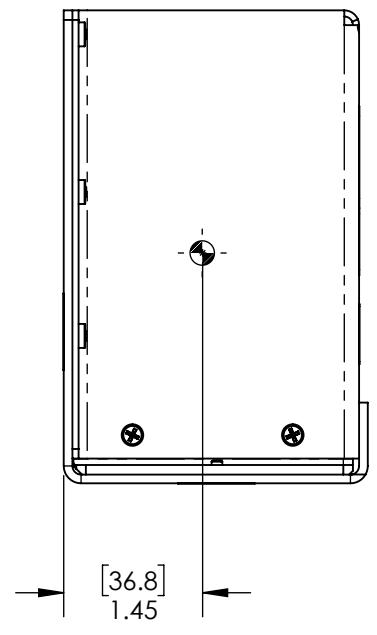
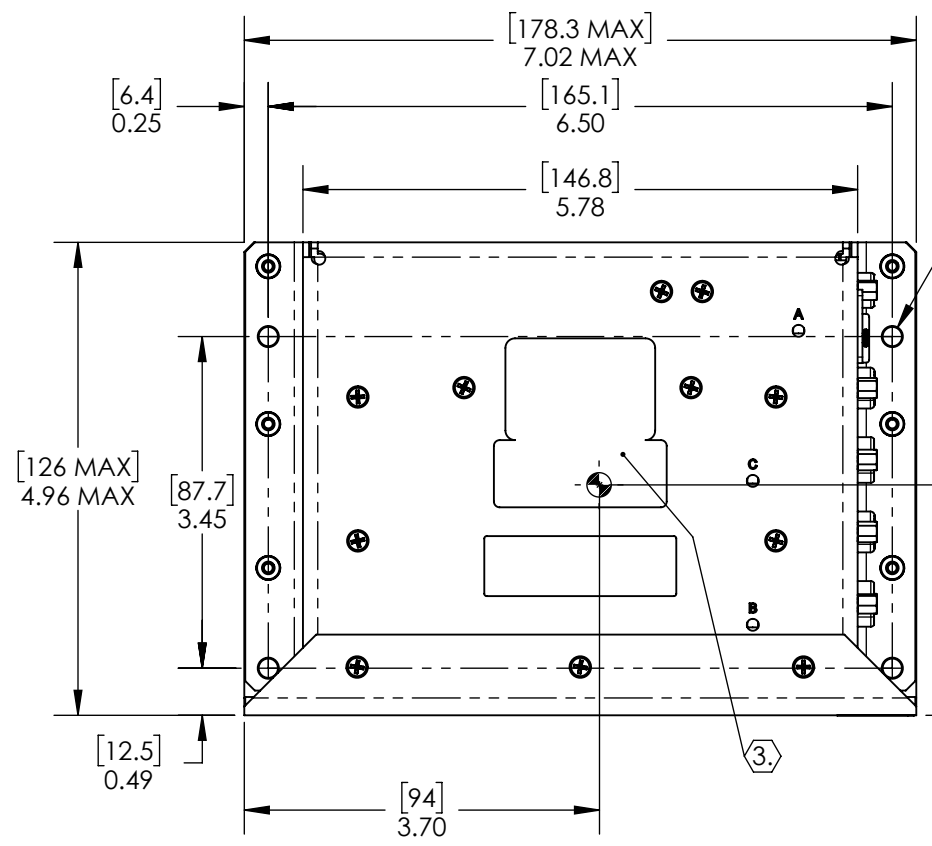
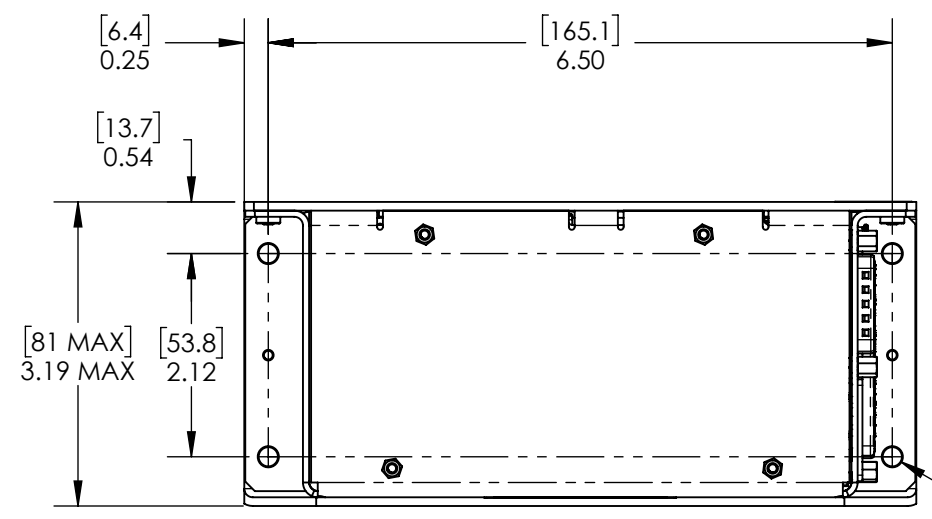

4X Ø 0.201 [5.11] THRU

4X Ø 0.201 [5.11] THRU

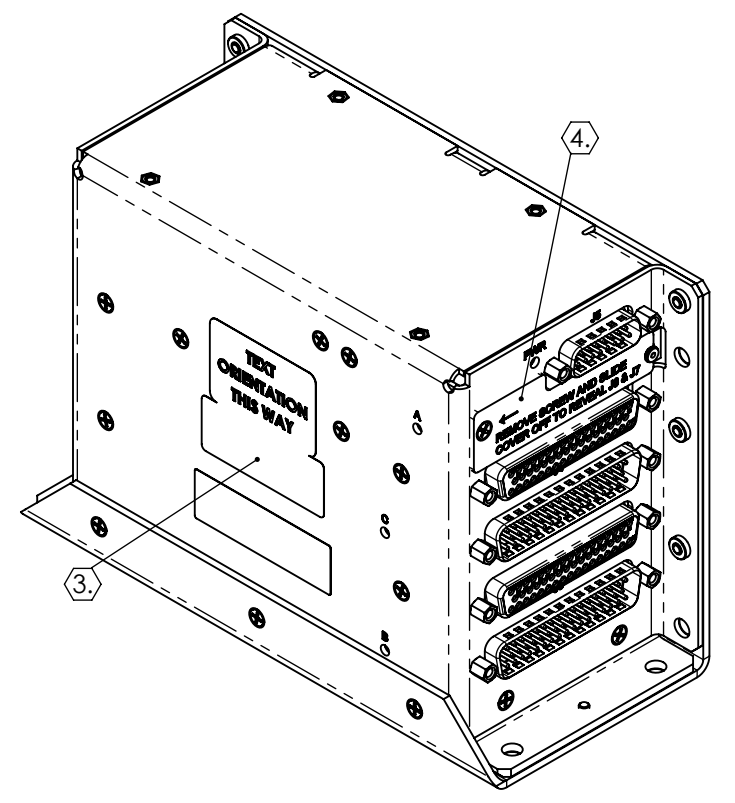
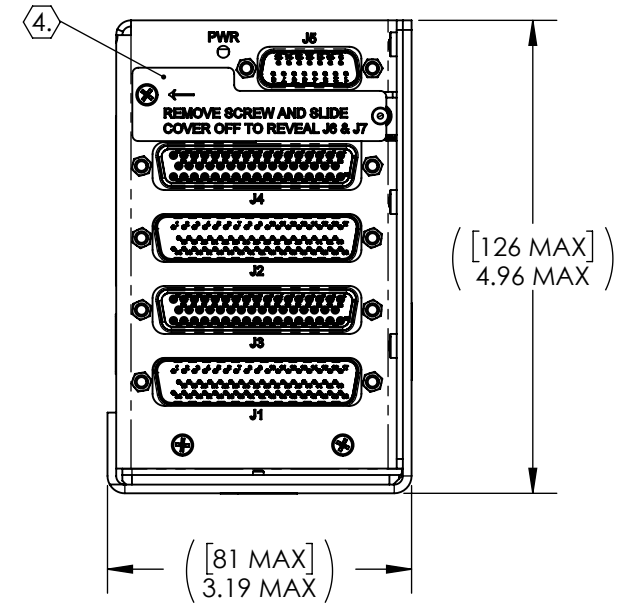

NOTES:

1. MASS 3.0 lb [1.4 kg] MAX
2. -●- DENOTES APPROXIMATE CENTER OF MASS
3. PRODUCT LABEL
4. J6 & J7 ACCESS PANEL

NAME	DATE	UNLESS OTHERWISE SPECIFIED:
DRAWN DMF	28-Aug-2024	DIMENSIONS ARE IN INCHES [MM]
CHECKED		TOLERANCES:
APPROVED		ANGULAR: ±0.5°
		FRACTIONAL: ±0.0625"
		ONE DECIMAL PLACE: ±0.100"
		TWO DECIMAL PLACE: ±0.030"
		THREE DECIMAL PLACE: ±0.010"
CONFIDENTIAL AND PROPRIETARY		MATERIAL:
THE INFORMATION CONTAINED IN THIS DRAWING IS THE SOLE PROPERTY OF ANODYNE ELECTRONICS MANUFACTURING. ANY REPRODUCTION IN PART OR AS A WHOLE WITHOUT THE WRITTEN PERMISSION OF ANODYNE ELECTRONICS MANUFACTURING IS PROHIBITED.		N/A
		FINISH:
		N/A

AEM ANODYNE ELECTRONICS MANUFACTURING CORP.

100-966 CROWLEY AVE.
KELOWNA BC V1Y 0L1
(250)-763-1088
WWW.AEM-CORP.COM

TITLE: **AUDIO ROUTER MECHANICAL INSTALLATION**

PAPER SIZE: B	CAGE CODE: L9015	PART No.: G13000R	REVISION: 1.20
SCALE: 1:2		DO NOT SCALE DRAWING	DRAWING No.: 922-0
			SHEET: 1 OF 1