



## G13115R One-Line Control Panel, Bluetooth Enabled P139-HD Installation and Operation Manual Supplement

---

This supplement contains installation and operation information that is unique to the G13115R Control Panel. Installation and operation information common to the G13115 unit can be found in the P139-HD Installation Manual and the P139-HD Digital Audio System User Manual.

Prepared By:	Checked By:	Approved By:
--------------	-------------	--------------

---

### Section 1.0 Description

---

#### 1.1 Product Description

---

The G13115R Control Panel is identical to the G13115 with the following exceptions:

- a) The G13115R has a physically reduced depth for shallow instrument panel installations.
- b) The G13115R has removed the J2 expansion connector.
- c) The G13115R contains a single Bluetooth® transceiver for connection to a single appropriate device if defined/configured as being active in the P139-HD factory system configuration file.

#### 1.2 Product Approval/Certification

---

The Bluetooth module used in the G13115R (BM64C2) has received regulatory approval for the following:

**Note:** While the BM64C2 Bluetooth module has received regulatory approval, the G13115R has not been tested for the following regulatory approvals.

BT SIG/QDID:	110148
United States/FCC ID:	A8TBM64S2
Canada/ISED:	IC:12246A-BM64S2 HVIN: BM64SPKS1MC2
Europe/CE	CE
Japan/MIC:	005-101205
Korea/KCC:	MSIP-CRM-mcp-BM64SPKS1MC2
Taiwan/NCC No:	CCAN16LP0280T8
China/SRRC:	CMIIT ID: 2016DJ2356
Brazil/ANATEL:	03822-18-08759



## G13115R One-Line Control Panel, Bluetooth Enabled P139-HD Installation and Operation Manual Supplement

### 1.2.1 United States - FCC

Contains FCC ID: A8TBM64S2 This device complies with Part 15 of the FCC Rules. Operation is subject to the following two conditions: (1) this device may not cause harmful interference, and (2) this device must accept any interference received, including interference that may cause undesired operation.

#### 1.2.1.1 Approved Antenna Information

Parameter	Values
Frequency	2400 MHz to 2480 MHz
Peak Gain	1.927 dBi
Efficiency	73.41%

Table 1: BM64 PCB Antenna Characteristics

Parameter	Values
Frequency	2.402 GHz to 2.480 GHz
Receiver Sensitivity	-90 dBm (2 Mbps EDR)
Output Power	+2 dBm typical

Table 2: RF/Analog Characteristics

This equipment has been tested and found to comply with the limits for a Class B digital device, pursuant to part 15 of the FCC Rules. These limits are designed to provide reasonable protection against harmful interference in a residential installation. This equipment generates, uses and can radiate radio frequency energy, and if not installed and used in accordance with the instructions, may cause harmful interference to radio communications. However, there is no guarantee that interference will not occur in a particular installation. If this equipment does cause harmful interference to radio or television reception, which can be determined by turning the equipment off and on, the user is encouraged to try to correct the interference by one or more of the following measures:

- Reorient or relocate the receiving antenna
- Increase the separation between the equipment and receiver
- Connect the equipment into an outlet on a circuit different from that to which the receiver is connected
- Consult the dealer or an experienced radio/TV technician for help



## G13115R One-Line Control Panel, Bluetooth Enabled P139-HD Installation and Operation Manual Supplement

### 1.2.2 Canada - ISED

This device contains license-exempt transmitters)/receiver(s) that comply with Innovation, Science and Economic Development Canada's license-exempt RSS (s). Operation is subject to the following two conditions:

- This device may not cause interference;
- This device must accept any interference, including interference that may cause undesired operation of the device.

L'émetteur/récepteur exempt de licence contenu dans le présent appareil est conforme aux CNR d'Innovation, Sciences et Développement économique Canada applicables aux appareils radio exempts de licence. L'exploitation est autorisée aux deux conditions suivantes:

- L'appareil ne doit pas produire de brouillage;
- L'appareil doit accepter tout brouillage radioélectrique subi, même si le brouillage est susceptible d'en compromettre le fonctionnement.

This radio transmitter [IC: 12246A-BM62S2, IC: 12246A-BM64S1 and IC: 12246A-BM64S2] has been approved by Innovation, Science and Economic Development Canada to operate with the antenna types listed in § 0 1.2.1.1 Approved Antenna Information with the maximum permissible gain indicated. Antenna types not included in this list that have a gain greater than the maximum gain indicated for any type listed are strictly prohibited for use with this device.

Le présent émetteur radio [IC: 12246A-BM62S2, IC: 12246A-BM64S1 and IC: 12246A-BM64S2] a été approuvé par Innovation, Sciences et Développement économique Canada pour fonctionner avec les types d'antenne énumérés § 0 1.2.1.1 Approved Antenna Information et ayant un gain admissible maximal. Les types d'antenne non inclus dans cette liste, et dont le gain est supérieur au gain maximal indiqué pour tout type figurant sur la liste, sont strictement interdits pour l'exploitation de l'émetteur.

### 1.2.3 Europe - CE

Certification	Standards	Article
Safety	EN 62368	3.1a
Health	EN 62311	
Electro Magnetic Compatibility (EMC)	EN 301 489-1	3.1b
	EN 301 489-17	
Radio	EN 300 328	3.2

Table 3: European Compliance



**G13115R One-Line Control Panel, Bluetooth Enabled  
P139-HD Installation and Operation Manual Supplement**

---

**1.2.4 Japan – MIC**

---

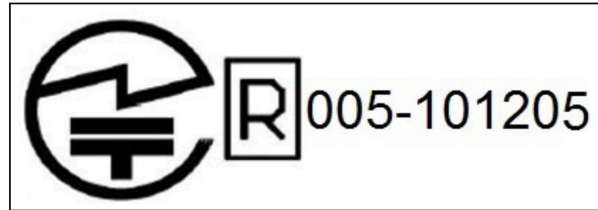

**1.2.5 Korea – KCC**

---

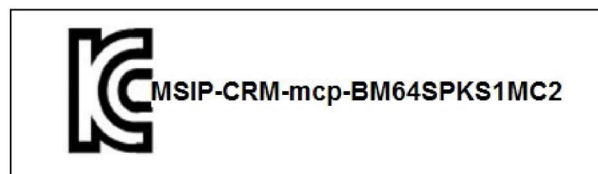

**1.2.6 Taiwan – NCC**

---



**注意！**

依據 低功率電波輻射性電機管理？法

第十二條 經型式認證合格之低功率射頻電機，非經許可，公司、商號或使用者均不得擅自變更頻率、加大功率或變更原設計之特性及功能。

第十四條 低功率射頻電機之使用不得影響飛航安全及干擾合法通信；經發現有干擾現象時，應立即停用，並改善至無干擾時方得繼續使用。前項合法通信，指依電信規定作業之無線電信。

低功率射頻電機須忍受合法通信或工業、科學及醫療用電波輻射性電機設備之干擾。



**G13115R One-Line Control Panel, Bluetooth Enabled  
P139-HD Installation and Operation Manual Supplement**

---

**1.2.7 China – SRRC**

---

This device contains SRRC approved Radio module CMIIT ID 2016DJ2356

CMIIT ID: 2016DJ2356

**1.2.8 Brazil – ANATEL**

---

Modelo: BM64SPKS1MC2



**03822-18-08759**

"Este equipamento não tem direito à proteção contra interferência prejudicial e não pode causar interferência em sistemas devidamente autorizados".

Este producto contém a placa Modelo  
BM64SPKS1MC2 código de homologação ANATEL  
03822-18-08759.



## G13115R One-Line Control Panel, Bluetooth Enabled P139-HD Installation and Operation Manual Supplement

---

### 1.2 Product Limitations

---

#### 1.2.1 Regulatory

---

As per FCC regulations stated in Title 47 CRF § 22.925 Prohibition on airborne operation of cellular telephones:

Cellular telephones installed in or carried aboard airplanes, balloons or any other type of aircraft must not be operated while such aircraft are airborne (not touching the ground). When any aircraft leaves the ground, all cellular telephones on board that aircraft must be turned off. The following notice must be posted on or near each cellular telephone installed in any aircraft:

“The use of cellular telephones while this aircraft is airborne is prohibited by FCC rules, and the violation of this rule could result in suspension of service and/or a fine. The use of cellular telephones while this aircraft is on the ground is subject to FAA regulations.”

#### 1.2.2 Multiple GNET Users

---

The G13000x router can only support up to 4 G13115R units per GNET bus before an external power source is required. Reference G13115R-403-0 Interconnect drawing.

## Section 2.0 Installation

---

### 2.1 Accessories Required but Not Supplied

---

Installation kit G13115M-IKC (crimp) is required to complete the installation. The kit consists of the following:

Qty	Description	Manufacturer	Mfr Part #	AEM Part #
1	D-Sub Socket Crimp 9P	MIL Spec	M24308/2-1F	120-21-007
1	D-Sub Plug Crimp 9P	MIL Spec	M24308/4-1F	120-11-004
2	Backshell DB9	Conec	165X11609XE	120-28-012
2	D-Sub Cable Clamp 3-12mm	Conec	160X11189XE	120-30-015

For installation information and drawings, see the P139-HD Installation Manual. The drawings specific to the G13115R are listed below and can be found at the end of this supplement.

### 2.2 Installation Drawings

---

DOCUMENT Part No.	REV.	DESCRIPTION	TYPE	SERIAL NO.
G13115R-403-0	1.01	Control Panel	Interconnect	116036 and up
G13115R-405-0	1.00	Control Panel	Connector Map	116036 and up
G13115R-922-0	1.00	Control Panel	Mechanical Installation	116036 and up



## G13115R One-Line Control Panel, Bluetooth Enabled P139-HD Installation and Operation Manual Supplement

---

### Section 3.0 Operation

---

For operation information, see the P139-HD Digital Audio System User Manual with the following exceptions/additions:

- a) Operational references to G13115 can also include G13115R.

#### 3.1 General

---

The Bluetooth module within the G13115R can interface with a single appropriate smart device for call and audio streaming.

##### 3.1.1 Connecting to a Bluetooth Device

---

To pair the G13115R with a Bluetooth smart device, the P139-HD factory system configuration file must first have the Bluetooth operation enabled for the intended unit on the appropriate GNET bus.

Ensure the G13115R unit is powered on and is connected to the P139-HD configured system.

As applicable, and/or per the system configuration file, turn on/enable the G13115R Bluetooth. E.g. pressing the appropriate G13115R front panel button or appropriate activation method, or if desired an always on condition as set in the system configuration file. AEM Technical Support can provide various options for this as part of the system configuration file creation process.

On the desired smart device to be paired, open the Bluetooth Settings to view the list of Available or Other Devices: AEM\_G13115R should be visible to select and pair with.

Enable audio streaming or call audio from the smart device.

- Notes:**
- a) Multiple Bluetooth users are allowed within a system that has multiple G13115R units. However, each one must be included as part of the P139-HD factory system configuration file and on which GNET bus.
  - b) During initial pairing, in a system with multiple Bluetooth enabled G13115R units, only one user at a time can perform the pairing process and care must be taken to ensure that the user is connected to the intended G13115R unit. Each G13115R must either be powered up separately or have the Bluetooth turned on/enabled one at a time.
  - c) The G13115R will automatically attempt to reconnect to the last connected Bluetooth device when turned on/enabled.
  - d) Applications used to make calls on a connected smart device must support standard Bluetooth profiles.
  - e) Smart devices may be able to rename the paired AEM\_G13115R to something familiar to the user. See applicable smart device manual for details.



## G13115R One-Line Control Panel, Bluetooth Enabled P139-HD Installation and Operation Manual Supplement

### 3.1.2 Troubleshooting

Problem	Solution(s)
AEM_G13115R not visible on Devices List	<ul style="list-style-type: none"><li>• Confirm G13115R and P139-HD system is powered on and otherwise functioning normally</li><li>• Check that the signed system configuration sheet lists the G13115R Bluetooth as active and on the appropriate GNET bus</li><li>• Contact AEM Technical Support to confirm that the MMC card configuration includes the Bluetooth enabled unit(s)</li></ul>
More than one AEM_G13115R is visible on Devices List	<ul style="list-style-type: none"><li>• G13115R units not powered up or turned on/enabled separately during initial pairing process.</li><li>• Turn off/disable un-used G13115R Bluetooth units</li></ul>
No call/streaming audio heard	<ul style="list-style-type: none"><li>• Verify smart device is paired to the AEM_G13115R</li><li>• Check the electrical interconnect between the G13115R and G13000x vs the signed system configuration</li><li>• Verify that audio is heard from other Radio positions to confirm issue is confined to the Bluetooth audio</li><li>• Internal fuse may have opened, unit should continue to operate as a non-Bluetooth enabled unit, return to AEM for service/repair assessment.</li></ul>

Supplement Ends After Attached Documents

REVISIONS			
REV	DESCRIPTION	DATE	BY
1.01	ECO1256 - SHEET 3: G13000x J3 PINS 35/36 CORRECTED	13-JAN-2026	AJV

G13115R INSTALLATION NOTES:

NOTES:

1. UNLESS OTHERWISE NOTED: ALL WIRES ARE 22 AWG; ALL SHIELDED WIRE IS MIL-DTL-27500; ALL UNSHIELDED WIRE IS MIL-W-22759/16.
2. ALL GROUNDING AND BONDING WILL BE I/A/W AC 43.13-1B, CHAPTER 1, SECTION 15.
3. GROUND THE SHIELD RETURN TO THE METAL CONNECTOR BACKSHELL IF USED, OR OTHERWISE TO THE METAL CONNECTOR HOUSING.
4. D50M CONNECTOR ASSEMBLY CONSISTS OF: CONNECTOR M24308/4-5F; CINCH BACKSHELL DD-24661-34; 2EA. CINCH SCREWLOCKS D20420-42. ALTERNATE BACKSHELL: CONEC 165X10179X.
5. D9F CONNECTOR ASSEMBLY CONSISTS OF: CONNECTOR M24308/2-1F; CINCH BACKSHELL DE-24657-30; 2EA. CINCH SCREWLOCKS D20419-46. ALTERNATE BACKSHELL: CONEC 165X10139X.
6. TERMINAL BLOCK ASSEMBLY CONSISTS OF: DEUTSCH BLOCK CTJ122E05E; DEUTSCH SOCKET CONTACTS CTS-S22/22 OR M39029/22-191. A GNET CHANNEL THAT IS CONNECTED TO ONLY ONE CONTROL PANEL OR OTHER DEVICE MAY BE WIRED DIRECTLY WITHOUT USING A TERMINAL BLOCK.
7. D15F CONNECTOR PREFERRED ASSEMBLY CONSISTS OF: CONNECTOR M24308/2-2F; CINCH BACKSHELL DA-24658-31; 2EA. CINCH SCREWLOCKS D20419-46. ALTERNATE BACKSHELL: CONEC P/N: 165X10149X. SPLICES ON 20 AWG WIRE SHALL ALSO BE 20 AWG, LENGTH 3 INCHES MAXIMUM. ALTERNATE ASSEMBLY CONSISTS OF: KOBICONN SOLDER-CUP CONNECTOR 156-1315T-E AND CINCH BACKSHELL DA-24658-31; 2EA. CINCH SCREWLOCKS D20419-46. ALTERNATE BACKSHELL: CONEC P/N: 165X10149X. CONDUCTORS SHOWN WITH SPLICES MAY BE IMPLEMENTED BY SOLDERING THE SUPPLY WIRE TO BOTH PINS AFTER SOLDERING AND INSULATING THE ADJACENT CONNECTIONS.

- 8
- 9
- 10
- 11

D9M CONNECTOR ASSEMBLY CONSISTS OF: CONNECTOR M24308/4-1F; CINCH BACKSHELL DE-24657-30; 2EA. CINCH SCREWLOCKS D20419-46. ALTERNATE BACKSHELL: CONEC 165X10139X.

SHIELDING: FOR SHIELDED WIRE, THE SHIELD MUST BE CONNECTED TO AIRFRAME GROUND OR CONNECTOR GROUND AS FOLLOWS:

- FOR WIRE CARRYING AUDIO SIGNALS, THE SHIELD MUST BE GROUNDED AT ONE END ONLY. GROUNDING BOTH ENDS MAY LEAD TO AUDIO NOISE.
- AUDIO SHIELD GROUND CONNECTIONS SHOULD BE MADE AT THE G13000 CONNECTORS BUT MAY BE MADE AT THE OTHER END AT THE INSTALLERS DISCRETION.
- FOR ALL OTHER SHIELDED WIRE, E.G. GNET AND POWER, THE SHIELD MUST BE GROUNDED AT BOTH ENDS.

BLUETOOTH AUDIO CONNECTIONS ONLY PRESENT ON BLUETOOTH ENABLED CONTROL HEADS. RECOMMEND ONLY ONE BLUETOOTH ENABLED CONTROL HEAD PER SYSTEM.

THE BLUETOOTH TRANSCEIVER LOCATED WITHIN THE G1311XR CONTROL HEAD MAY BE ROUTED TO ANY AVAILABLE RADIO PORT ON THE AUDIO ROUTER. ACTIVATION AND ROUTING OF THE BLUETOOTH AUDIO IS CONTROLLED BY THE CONFIGURATION INSTALLED WITHIN THE AUDIO ROUTER.

DEFINITIONS:

- N/C: NO CONNECTION. THE PIN IS NOT CONNECTED TO ANYTHING INTERNALLY, AND THEREFORE SHALL HAVE NO CONNECTION EXTERNALLY.
- N/C SPARE: NO CONNECTION INTERNALLY, BUT A SPARE WIRE SHALL BE INSTALLED IN THE WIRE HARNESS.
- RESERVED: MAY BE CONNECTED AND USED IN THE FUTURE. THE CIRCUITRY MAY BE PRESENT OR ADDED TO ACTIVATE THE FUNCTION. THE PIN MAY BE USED FOR TEST PURPOSES. THERE IS NO EXTERNAL CONNECTION.
- RESERVED, SPARE: RESERVED, BUT INSTRUCTIONS SHALL BE FOLLOWED TO ACTIVATE THE CIRCUITRY. A SPARE WIRE SHALL BE INSTALLED IN THE WIRE HARNESS.

NAME		DATE	UNLESS OTHERWISE SPECIFIED:		 <b>ANODYNE ELECTRONICS MANUFACTURING CORP.</b>	KELOWNA BC CANADA (250)-763-1088 WWW.AEM-CORP.COM	
DRAWN	AJV	21-Oct-2024	DIMENSIONS ARE IN INCHES [MM]			TITLE: CONTROL PANEL, NOTES INTERCONNECT	
CHECKED			TOLERANCES:		PAPER SIZE: B CAGE CODE: L9015 PART NO.: G13115R REVISION: 1.01		
APPROVED			FRACTIONAL: ±0.0625"		SCALE: 1:1 DO NOT SCALE DRAWING DRAWING No.: 403-0 SHEET: 1 of 3		
<b>CONFIDENTIAL AND PROPRIETARY</b> THE INFORMATION CONTAINED IN THIS DRAWING IS THE SOLE PROPERTY OF ANODYNE ELECTRONICS MANUFACTURING. ANY REPRODUCTION IN PART OR AS A WHOLE WITHOUT THE WRITTEN PERMISSION OF ANODYNE ELECTRONICS MANUFACTURING IS PROHIBITED.			ANGULAR: ±0.5°				
			TWO DECIMAL PLACE: ±0.010"		THREE DECIMAL PLACE: ±0.005"		
			MATERIAL: N/A				
			FINISH: N/A				

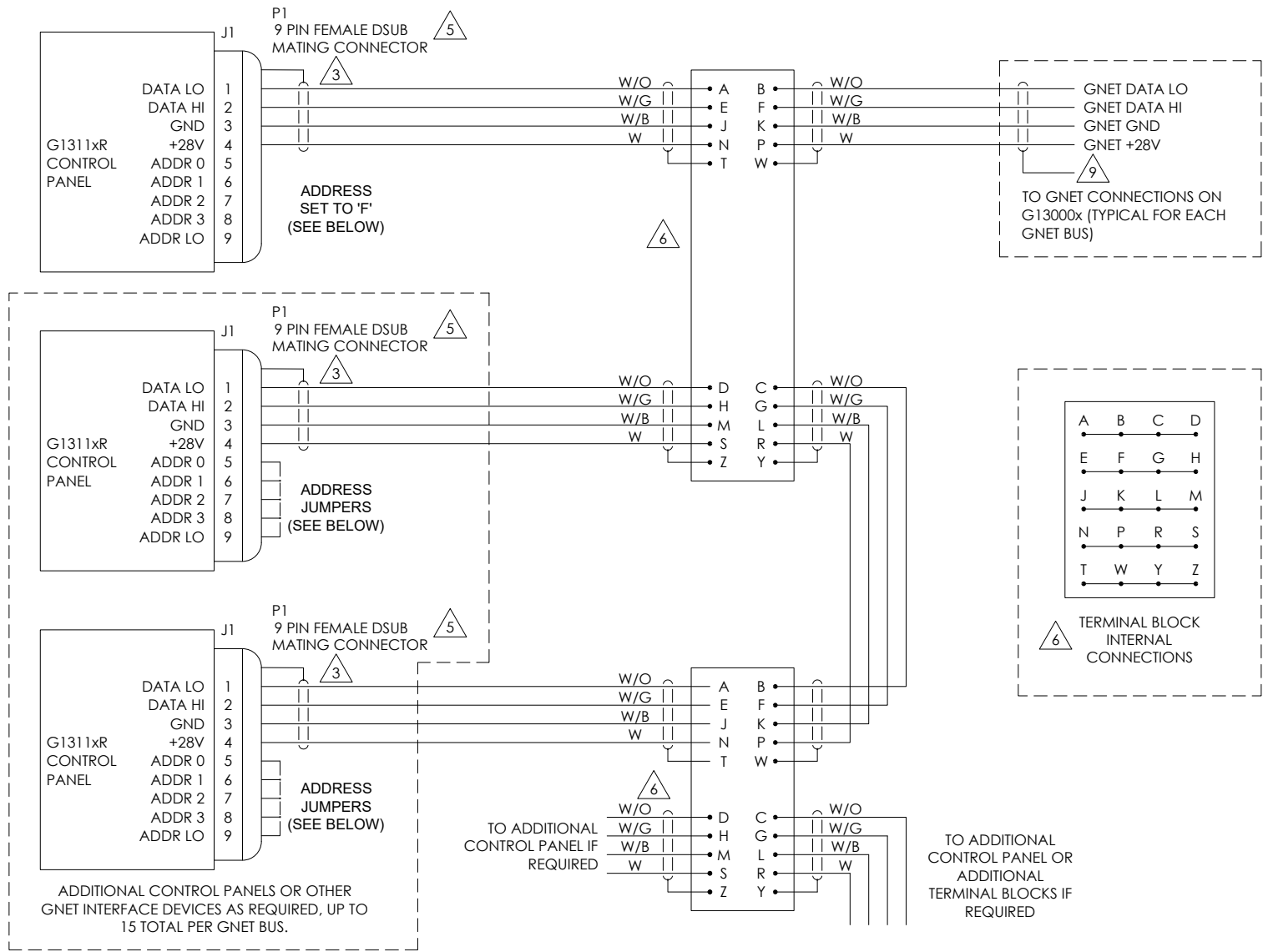

**CONTROL PANEL BUS ASSIGNMENT:**

IF THE NUMBER OF INSTALLED CONTROL PANELS IS EQUAL TO OR LESS THAN THE NUMBER OF AVAILABLE GNET BUSES (4 FOR DUAL-BOARD ROUTERS: G13000 OR G13000R, 2 FOR SINGLE-BOARD ROUTER: G13000(S)), THEN EACH PANEL SHOULD BE CONNECTED TO A SEPARATE GNET BUS AND TERMINAL BLOCKS ARE NOT REQUIRED.

THE PILOT'S PRIMARY CONTROL PANEL SHOULD BE THE FIRST DEVICE ON GNET BUS 1. THE COPILOT'S PRIMARY CONTROL PANEL SHOULD BE THE FIRST DEVICE ON GNET 3 IN A DUAL-BOARD SYSTEM: G13000 OR G13000R, AND THE FIRST DEVICE ON GNET 2 ON A SINGLE-BOARD SYSTEM: G13000(S).

ADDITIONAL CONTROL PANELS SHOULD BE EVENLY DISTRIBUTED AMONG AVAILABLE GNET BUSES.

**GNET ADDRESS JUMPERS:**

FOR EVERY CONTROL PANEL OR OTHER PERIPHERAL DEVICE CONNECTED TO A PARTICULAR GNET BUS, A UNIQUE DEVICE ADDRESS FROM "1" TO "9" OR "A" TO "F" MUST BE WIRED INTO THE CONNECTOR. THE ADDRESS FOR EACH DEVICE ON EACH GNET BUS IS DEFINED IN THE SYSTEM CONFIGURATION SOFTWARE FOR THE SPECIFIC INSTALLATION.

USING 24 AWG WIRE 1.5" LONG FOR EACH JUMPER, CONNECT THE FOLLOWING PINS TOGETHER FOR GNET ADDRESSING FOR EACH CONNECTOR, AS SPECIFIED IN THE SYSTEM CONFIGURATION REQUIREMENTS. MAKE NO CONNECTIONS TO UNLISTED PINS.

THE FIRST CONTROL PANEL ON ANY GIVEN GNET BUS SHOULD BE SET AS ADDRESS "F" WITH NO JUMPERS. ADDITIONAL PANELS ON THE SAME BUS SHOULD BE GIVEN ADDRESSES IN DESCENDING ORDER: "E", "D", "C" ETC.

- "1" = 6-7-8-9
- "2" = 5-7-8-9
- "3" = 7-8-9
- "4" = 5-6-8-9
- "5" = 6-8-9
- "6" = 5-8-9
- "7" = 8-9
- "8" = 5-6-7-9
- "9" = 6-7-9
- "A" = 5-7-9
- "B" = 7-9
- "C" = 5-6-9
- "D" = 6-9
- "E" = 5-9
- "F" = NONE

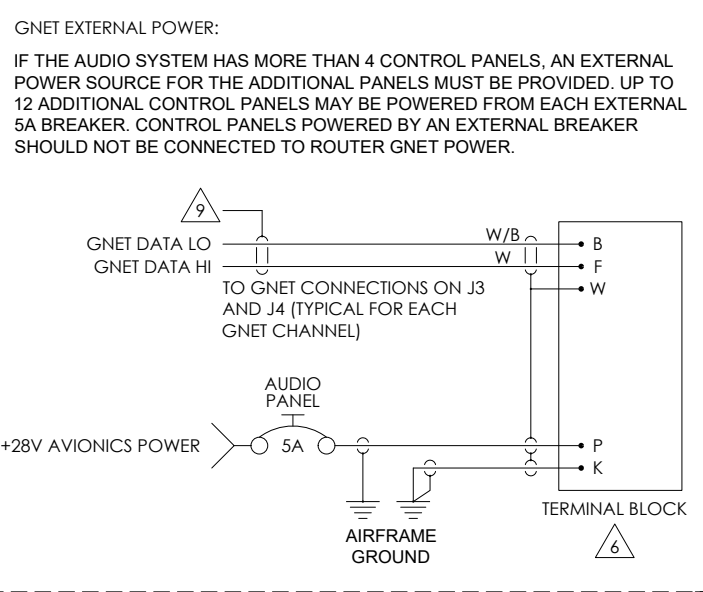

**GNET EXTERNAL POWER:**

IF THE AUDIO SYSTEM HAS MORE THAN 4 CONTROL PANELS, AN EXTERNAL POWER SOURCE FOR THE ADDITIONAL PANELS MUST BE PROVIDED. UP TO 12 ADDITIONAL CONTROL PANELS MAY BE POWERED FROM EACH EXTERNAL 5A BREAKER. CONTROL PANELS POWERED BY AN EXTERNAL BREAKER SHOULD NOT BE CONNECTED TO ROUTER GNET POWER.

NAME	DATE	UNLESS OTHERWISE SPECIFIED:
DRAWN AJV	21-Oct-2024	DIMENSIONS ARE IN INCHES (MM)
CHECKED		TOLERANCES:
APPROVED		FRACTIONAL ±0.0625"
		ANGULAR ±0.5°
		TWO DECIMAL PLACE ±0.010"
		THREE DECIMAL PLACE ±0.005"
CONFIDENTIAL AND PROPRIETARY THE INFORMATION CONTAINED IN THIS DRAWING IS THE SOLE PROPERTY OF ANODYNE ELECTRONICS MANUFACTURING. ANY REPRODUCTION IN PART OR AS A WHOLE WITHOUT THE WRITTEN PERMISSION OF ANODYNE ELECTRONICS MANUFACTURING IS PROHIBITED.		MATERIAL: N/A
		FINISH: N/A

**ANODYNE ELECTRONICS MANUFACTURING CORP.**

KELOWNA BC CANADA  
(250)-763-1088  
WWW.AEM-CORP.COM

TITLE: **CONTROL PANEL, GNET INTERCONNECT**

PAPER SIZE: B	CAGE CODE: L9015	PART NO.: G13115R	REVISION: 1.01
SCALE: 1:1	DO NOT SCALE DRAWING	DRAWING No.: 403-0	SHEET: 2 of 3

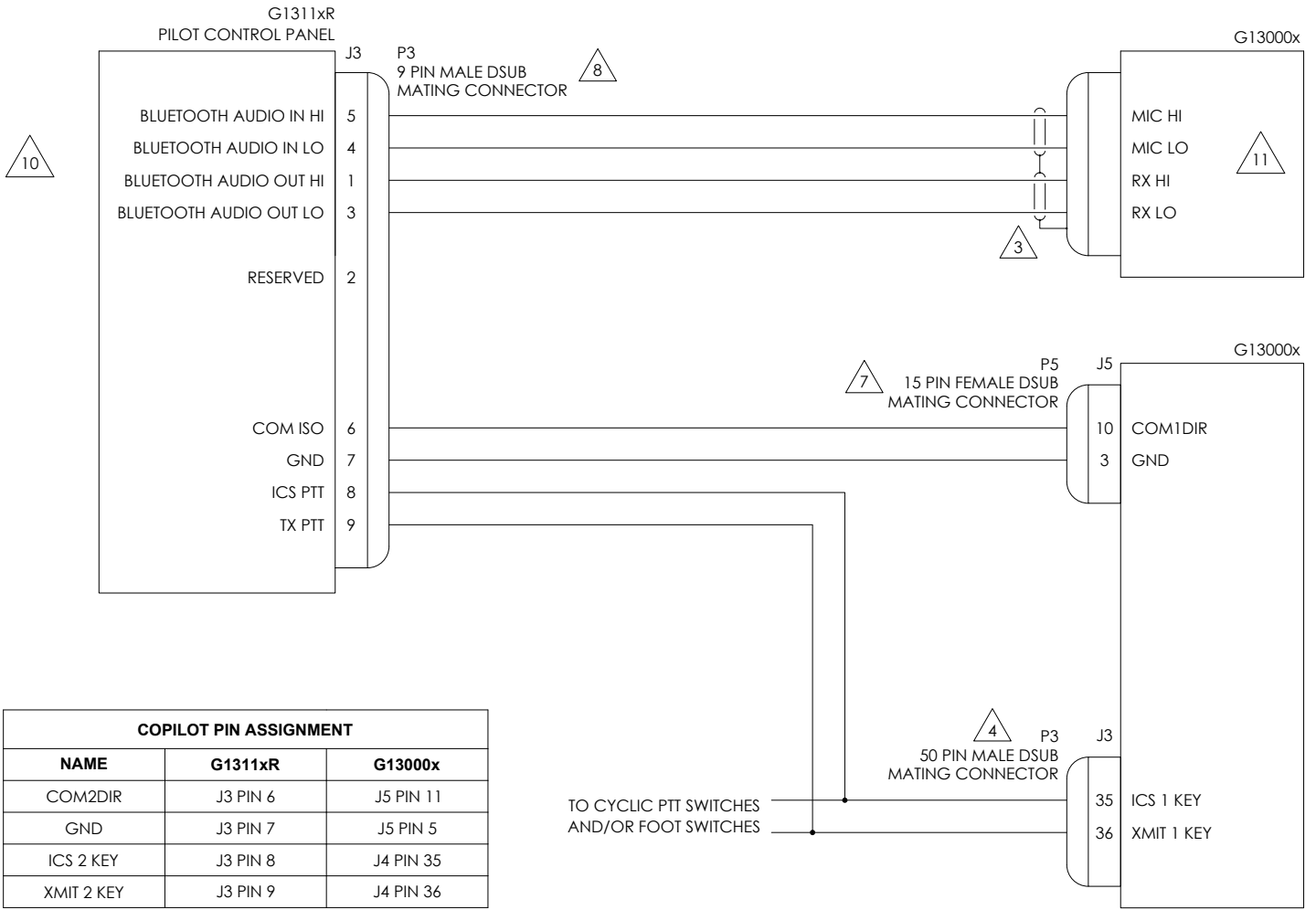

THE G1311xR CONTROL PANELS HAVE TWO ELECTROMECHANICAL TOGGLE SWITCHES ON THE FRONT PANEL: AN EMERG/NORMAL LOCKING TOGGLE SWITCH, AND A 3-POSITION MOMENTARY SWITCH FOR ICS/OFF/TX PTT. WHEN EACH SWITCH IS "ON" THE APPROPRIATE PIN ON THE J3 CONNECTOR IS CONNECTED TO GND, PIN 7.

THE ABOVE WIRING DIAGRAM ILLUSTRATES THE USE OF THE EMERG/NORMAL SWITCH ON THE PILOT'S G1311xR PRIMARY CONTROL PANEL TO CONTROL THE EMERGENCY MODE OPERATION FOR THE PILOT HEADSET. THE OPERATION OF THE DIGITAL AUDIO SYSTEM IN EMERGENCY MODE IS DETAILED ON G13000x INTERCONNECT DRAWING.

THE PILOT'S PRIMARY CONTROL PANEL MUST BE WIRED TO COM1DIR AS SHOWN IF THIS IS THE PRIMARY AUDIO SYSTEM INSTALLED. ONLY IF THE AUDIO SYSTEM IS INSTALLED AS A SECONDARY MAY THE CONNECTION BE OMITTED AND THE COM1DIR PIN ON THE G13000x BE DIRECTLY CONNECTED TO GROUND.

IN MOST INSTALLATIONS, THE COPILOT'S PRIMARY CONTROL PANEL WILL BE WIRED TO COM2DIR, CONNECTING TO THE APPROPRIATE PINS AS SHOWN IN THE ABOVE TABLE. EXCEPTIONS ARE IF THE AUDIO SYSTEM IS NOT THE PRIMARY AUDIO SYSTEM OR IF THE HEADSET 2 PORT IS NOT AT A LOCATION USED BY FLIGHT CREW. IN THESE SITUATIONS THE COM2DIR PIN ON THE G13000x SHOULD BE DIRECTLY CONNECTED TO GROUND.

ON A SINGLE-BOARD SYSTEM: G13000(S), THERE IS NO COPILOT EMERGENCY MODE, AND THE COM2DIR PIN IS NOT CONNECTED.

THE EMERG/NORMAL SWITCH IS ONLY CONNECTED FOR THE PILOT'S AND COPILOT'S PRIMARY CONTROL PANEL. FOR OTHER CONTROL PANEL LOCATIONS, THE EMERG/NORMAL SWITCH HAS NO FUNCTION AND COM/ISO SHOULD NOT BE WIRED.

THE ICS PTT AND TX PTT PINS ON THE COPILOT CONTROL PANEL SHOULD BE CONNECTED IN PARALLEL WITH THE APPROPRIATE PTT SWITCHES ON THE COPILOT CYCLIC AND/OR FOOT SWITCHES.

IN ALL OTHER CREW POSITIONS THE ICS PTT AND TX PTT PINS ON THE ASSOCIATED CONTROL PANEL MAY BE CONNECTED IN PARALLEL WITH THE APPROPRIATE PTT SWITCHES FOR THAT HEADSET.

NAME	DATE	UNLESS OTHERWISE SPECIFIED:	AEM ANODYNE ELECTRONICS MANUFACTURING CORP.		KELOWNA BC CANADA (250)-763-1088 WWW.AEM-CORP.COM
DRAWN	AJV	21-Oct-2024	DIMENSIONS ARE IN INCHES [MM]		
CHECKED			TOLERANCES: FRACTIONAL ±0.0625" ANGULAR ±0.5° TWO DECIMAL PLACE ±0.010" THREE DECIMAL PLACE ±0.005"		
APPROVED			MATERIAL: N/A		
<b>CONFIDENTIAL AND PROPRIETARY</b> THE INFORMATION CONTAINED IN THIS DRAWING IS THE SOLE PROPERTY OF ANODYNE ELECTRONICS MANUFACTURING. ANY REPRODUCTION IN PART OR AS A WHOLE WITHOUT THE WRITTEN PERMISSION OF ANODYNE ELECTRONICS MANUFACTURING IS PROHIBITED.			FINISH: N/A		<b>CONTROL PANEL WIRING INTERCONNECT</b> PAPER SIZE: B CAGE CODE: L9015 PART No.: G13115R REVISION: 1.01 SCALE: 1:1 DO NOT SCALE DRAWING DRAWING No.: 403-0 SHEET: 3 of 3
			MATERIAL: N/A		

P1

9 PIN FEMALE DSUB  
MATING CONNECTOR

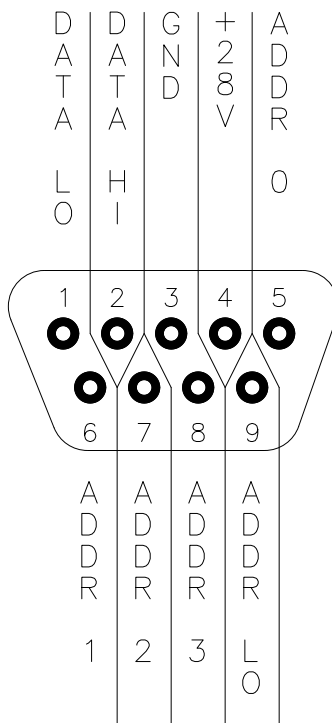

VIEW IS FROM REAR OF AIRFRAME CONNECTOR

	NAME	DATE	UNLESS OTHERWISE SPECIFIED:		 <b>ANODYNE ELECTRONICS MANUFACTURING CORP.</b>	KELOWNA BC CANADA (250)-763-1088 WWW.AEM-CORP.COM		
DRAWN	AJV	21-Oct-2024	DIMENSIONS ARE IN INCHES [MM] TOLERANCES: FRACTIONAL _____ ±0.0625" ANGULAR _____ ±0.5° TWO DECIMAL PLACE _____ ±0.010" THREE DECIMAL PLACE _____ ±0.005"			TITLE:		
CHECKED			MATERIAL:		CONTROL PANEL CONNECTOR MAP			
APPROVED			FINISH:					PAPER SIZE:
<b>CONFIDENTIAL AND PROPRIETARY</b> THE INFORMATION CONTAINED IN THIS DRAWING IS THE SOLE PROPERTY OF ANODYNE ELECTRONICS MANUFACTURING. ANY REPRODUCTION IN PART OR AS A WHOLE WITHOUT THE WRITTEN PERMISSION OF ANODYNE ELECTRONICS MANUFACTURING IS PROHIBITED.			NA		A	L9015	G13115R	
			NA		SCALE: 1:1	DO NOT SCALE DRAWING	DRAWING No.: 405-0	REVISION 1.00
								SHEET: 1 of 2

P3

9 PIN MALE DSUB  
MATING CONNECTOR

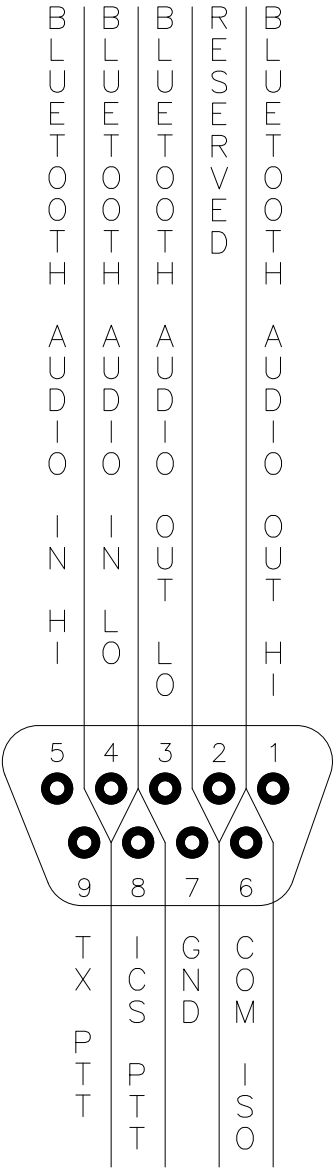

VIEW IS FROM REAR OF AIRFRAME CONNECTOR

	NAME	DATE	UNLESS OTHERWISE SPECIFIED:			KELOWNA BC CANADA (250)-763-1088 WWW.AEM-CORP.COM	
DRAWN	AJV	21-Oct-2024	DIMENSIONS ARE IN INCHES [MM] TOLERANCES: FRACTIONAL _____ ±0.0625" ANGULAR _____ ±0.5° TWO DECIMAL PLACE _____ ±0.010" THREE DECIMAL PLACE _____ ±0.005"				
CHECKED				TITLE: CONTROL PANEL CONNECTOR MAP			
APPROVED							
CONFIDENTIAL AND PROPRIETARY THE INFORMATION CONTAINED IN THIS DRAWING IS THE SOLE PROPERTY OF ANODYNE ELECTRONICS MANUFACTURING. ANY REPRODUCTION IN PART OR AS A WHOLE WITHOUT THE WRITTEN PERMISSION OF ANODYNE ELECTRONICS MANUFACTURING IS PROHIBITED.			MATERIAL:	NA		REVISION	
			FINISH:	NA		1.00	
			PAPER SIZE:	CAGE CODE	PART No.:		
			A	L9015	G13115R		
			SCALE: 1:1	DO NOT SCALE DRAWING	DRAWING No.: 405-0		SHEET: 2 of 2

8 7 6 5 4 3 2 1

D

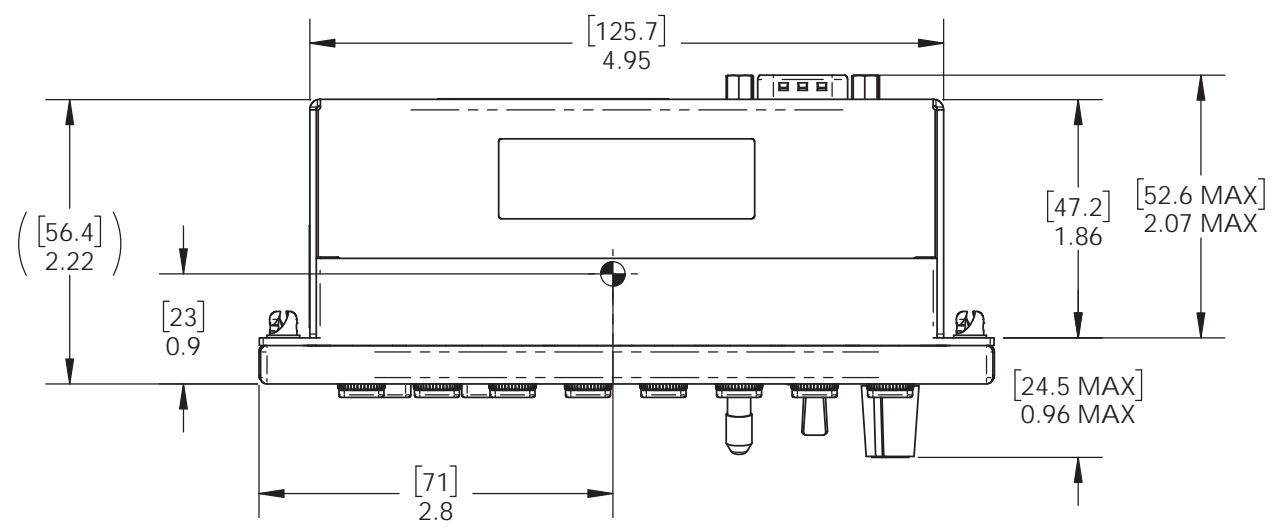

- NOTES:
1. MASS: 1.24 lb [0.56 kg] MAX
  2. DENOTES ESTIMATED CENTER OF MASS.
  3. BUTTON & PANEL LABELS ARE INSTALLER DEFINED.

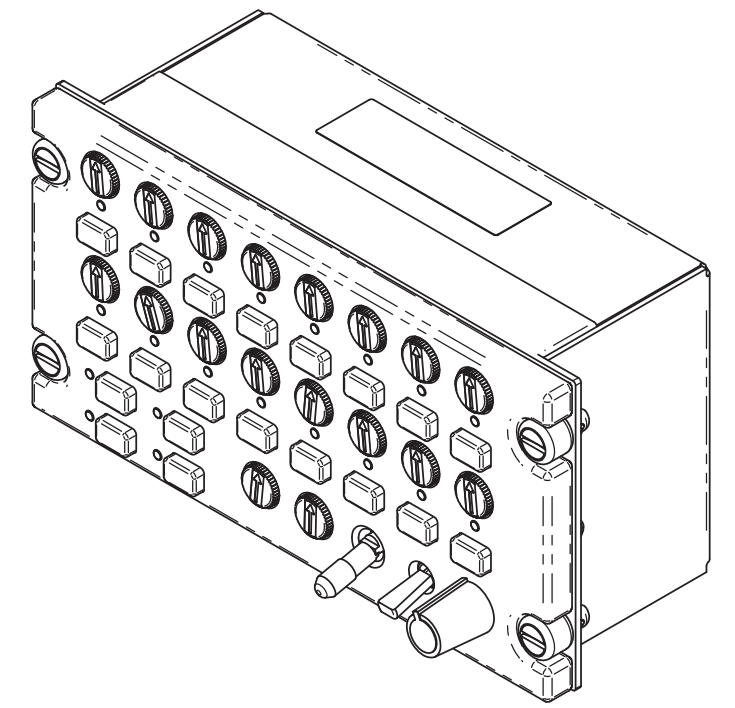

D

C

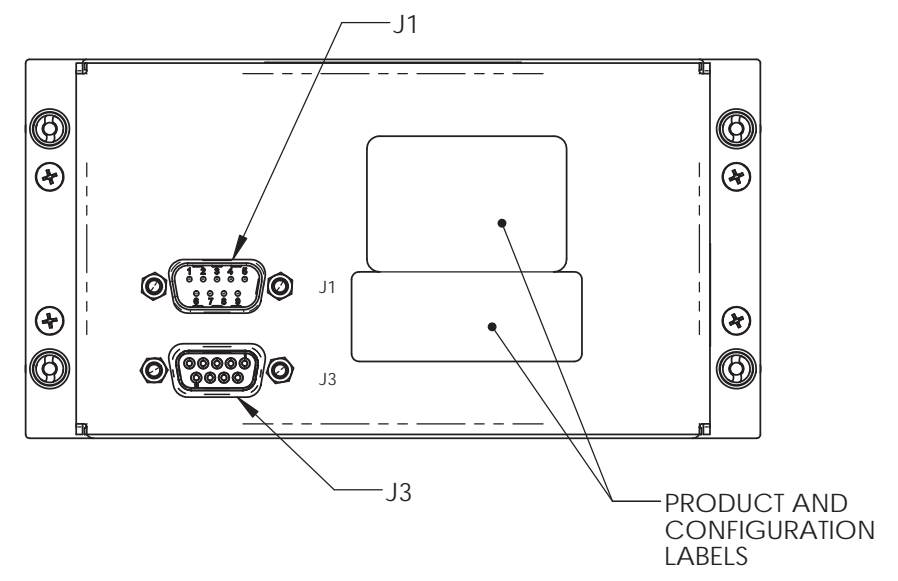
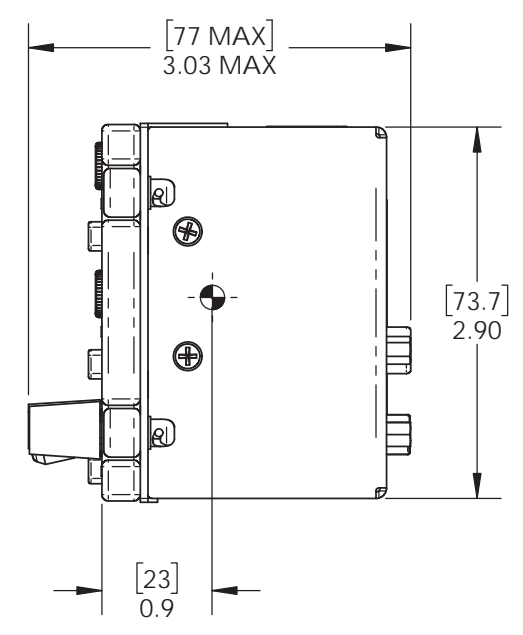
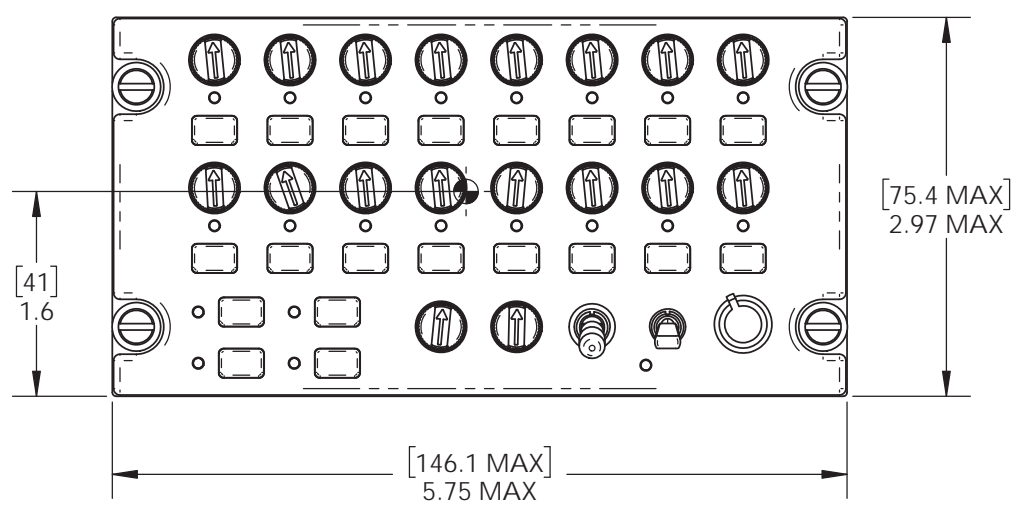

C

B

B

A

A

	NAME	DATE	UNLESS OTHERWISE SPECIFIED:		100-966 CROWLEY AVE. KELOWNA BC V1Y 0L1 (250)-763-1088 WWW.AEM-CORP.COM
DRAWN	AJV	02-Sep-2025	DIMENSIONS ARE IN INCHES [MM]		
CHECKED		2-Sep-2025	TOLERANCES:		
APPROVED		05-Sep-2025	ANGULAR: ±2° FRACTIONAL: +0.125" ONE DECIMAL PLACE: +0.100" TWO DECIMAL PLACE: +0.030" THREE DECIMAL PLACE: +0.010"		
CONFIDENTIAL AND PROPRIETARY THE INFORMATION CONTAINED IN THIS DRAWING IS THE SOLE PROPERTY OF ANODYNE ELECTRONICS MANUFACTURING. ANY REPRODUCTION IN PART OR AS A WHOLE WITHOUT THE WRITTEN PERMISSION OF ANODYNE ELECTRONICS MANUFACTURING IS PROHIBITED.			MATERIAL:	TITLE: <b>CONTROL PANEL MECHANICAL INSTALLATION</b>	
			FINISH:	PAPER SIZE: B CAGE CODE: L9015 SCALE: 2:3	PART No.: G13115R DO NOT SCALE DRAWING DRAWING No.: 922-0
				REVISION: 1.00	SHEET: 1 OF 1

8 7 6 5 4 3 2 1