



Installation Manual

MTP138

Mission Transceiver Panel Mount



INSTALLATION MANUAL

MTP138-000GN-815-0 REV 1.00
February 12, 2026

Anodyne Electronics Manufacturing Corp.
966 Crowley Ave Unit #100
Kelowna, BC, Canada.
V1Y 0L1

Telephone: +1-250-763-1088
Toll Free: +1-888-763-1088

Website: www.aem-corp.com

© 2026 Anodyne Electronics Manufacturing Corp. (AEM)

All Rights Reserved**COPYRIGHT STATEMENT**

© 2026 Anodyne Electronics Manufacturing Corp. (AEM), All Rights Reserved

This publication is the property of AEM and is protected by Canadian copyright laws. No part of this document may be reproduced or transmitted in any form or by any means including electronic, mechanical, photocopying, recording, or otherwise, without the prior written permission of AEM.

INTELLECTUAL PROPERTY RIGHTS

This product may be protected by one or more patents or designs of Tait Electronics Limited together with their international equivalents, pending patents, or design applications and registered Trade Marks: NZ409837, NZ409838, NZ508806, NZ508807, NZ509242, NZ509640, NZ509959, NZ510496, NZ511155, NZ511421, NZ516280, NZ519742, NZ520650, NZ537902, NZ521450, NZ522236, NZ524369, NZ524378, NZ524509, NZ524537, NZ524630, NZ530819, NZ534475, NZ534692, NZ535471, NZ537434, NZ546295, NZ547713, NZ569985, AU2003281447, AU2004216984, AU2005207405, AU2005267973, AO200811677, CA2554213, CA2574670, CN200830113833.4, EU1,532,866, EU1,599,792, EU0574655.9, EU000915475, GB23865476, GB23860110, GB2413249, GB2413445, US11/232716, US10/597339, US10/520827, US5,745,840, US10/547653, US10/546696, US10/546697, US10/520827, US10/547964, US10/523952, US11/572700, US29/306491.

This product may also be made under license under one or more of the following U.S. Patents: 4,590,473, 4,636,791, 4,716,407, 4,972,460, 5,146,497, 5,148,482, 5,164,986, 5,185,795, 5,185,796, 5,271,017, 5,377,229, and 5,502,767.

The IMBE™ voice decoding Technology embodied in this product is protected by Intellectual Property Rights including patent rights, copyrights, and trade secrets of Digital Voice Systems, Inc. This voice coding Technology is licensed solely for use within this Communication Equipment. The user of this Technology is explicitly prohibited from attempting to decompile, reverse engineer, or disassemble the Object Code, or in any other way convert the Object Code into a human-readable form. Protected by U.S. Patents 5,870,405, 5,826,222, 5,754,974, 5,701,390, 5,715,365, 5,649,050, 5,630,011, 5,581,656, 5,517,511, 5,491,772, 5,247,579, 5,226,084, and 5,195,166.

Firmware Copyrights: The title to and ownership of copyrights for firmware embedded in this product and memories are reserved for Anodyne Electronics Manufacturing Corp and other respective owners.

Table of Contents

SECTION 1.0 DESCRIPTION	1
1.1 Introduction	1
1.2 Product Description.....	1
1.3 Features	2
1.4 Specifications.....	3
1.4.1 Technical Characteristics.....	3
1.4.2 Summary of DO-160G Environmental Test Conditions	4
1.5 Product Approval/Certification.....	5
1.6 Product Limitations	5
1.7 Unit Nomenclature	6
1.8 Key Enabled Features	6
1.9 Regulatory Statements.....	7
1.9.1 ISED General Statements.....	7
1.9.2 ISED Additional Statement for Detachable Antenna	7
1.9.3 FCC Statements for Class A Digital Device	8
1.9.4 Radio Frequency Exposure Information.....	8
1.9.5 Health Canada Warning Statement.....	9
1.9.6 FCC Narrowbanding Regulations	10
SECTION 2.0 INSTALLATION	11
2.1 Introduction	11
2.2 Unpacking and Inspection.....	11
2.3 Warranty	11
2.4 Installation Kit	11
2.5 Front Panel	12
2.6 Warnings	13
2.7 Antennas	13
2.8 System Interface Connector.....	16
2.9 Wiring Diagrams	16
2.10 Additional Wiring Information	20
2.11 Electrical Bonding	20
2.12 Pre-Installation Checks	21
2.13 Post-Installation Checks.....	22
2.14 Post Installation Adjustments	23
2.14.1 MTP Firmware Versions	23
2.15 Airworthiness Approval Notes	30
2.15.1 Instructions for Continued Airworthiness.....	30
2.16 Post Installation EMI Test	30
2.17 Troubleshooting	31
APPENDIX A: INSTALLATION OPTIONS AND SETTINGS	33
Admin Options.....	33
User Options	34
Radio.....	36
APPENDIX B: ENVIRONMENTAL QUALIFICATION FORMS	37

List of Figures

Figure 1: MTP	1
Figure 2: MTP Front Panel	12
Figure 3: Connector J1 and Antenna J2 Locations	14
Figure 4: MTP Outer Dimensions (inches)	14
Figure 5: MTP Behind Panel Dimensions (inches)	15
Figure 6: J1 System Interface Connector Map	16
Figure 6: Interconnect Drawing for MTP138	16
Figure 7: Interconnect Drawing for MTP	17
Figure 8: Alternate Interconnect Drawing for MTP	18
Figure 9: Interconnect Drawing Notes	19

List of Tables

Table 1: Summary of DO-160G Environmental Testing	4
Table 2: Unit Nomenclature	6
Table 3: Approved Antennas	8
Table 4: Installation Kit Content	11
Table 5: Front Panel Controls	12
Table 6: J1 System Interface Connector Pins	16
Table 7: Pre-Installation Continuity Checks	21
Table 8: Pre-Installation Voltage Checks	21
Table 9: Post Installation Checks	22
Table 10: MTP Firmware Versions	22
Table 11: Permission Levels	23
Table 12: Agile Edit and Wideband Keys	23
Table 13: Profile Hashes	29
Table 14: Installation Troubleshooting Guide	32
Table 15: MTP Admin Options	34
Table 16: User Options	35
Table 17: Radio Options	36

Abbreviations and Acronyms

Abbreviation	Definition
AEM	Anodyne Electronics Manufacturing Corp.
APCO	Association of Public-Safety Communications Officials- International
BNC	Bayonet Neill Concelman
CAR	Civil Aviation Regulations
CDCSS	Continuous Digital Code Squelch System
CTCSS	Continuous Tone Code Squelch System
DTMF	Dual Tone Multiple Frequency
ELT	Emergency Locator Transmitter
FAA	Federal Aviation Administration
FCC	Federal Communication Committee
FM	Frequency Modulation
GND	Ground
ICA	Instructions for Continued Airworthiness
ICNIRP	International Commission on Non-Ionizing Radiation Protection
ID	Identification

Abbreviation	Definition
IEEE	Institute of E lectrical and E lectronics E ngineers
IKC	Installation K it C rimp
ISED	Innovation, S cience and E conomic D evelopment Canada
MIC	M icrophone
Mon	M onitor
MTP	M ission T ransceiver P anel M ount
NAC	N etwork A ccess C ode
NVIS	N ight V ision
PL	P rivate L ine
PTT	P ush T o T alk
RF	R adio F requency
RSS	R adio S tandards S pecifications
RX	R eceive
STD	S tandard
STC	S upplemental T ype C ertificate
TC	T ype C ertificate
TCCA	T ransport C anada C ivil A viation
TGID	T alk G roup I dentifier
TIA	T elecommunications I ndustry A ssociation
TX	T ransmit
USB	U niversal S erial B us
VHF	V ery H igh F requency

Glossary of Terms

Term	Definition
Active Channel	The channel that is displayed by the Focused Radio.
Active Low	A function that operates (ON) when the signal input is low (0V).
Active Zone	The zone that is displayed for the Active Channel.
Agile Edit	Allows for edits to be made to Lists (zones, channels, tones, codes, NAC, TGID) during flight.
Codes	This term is synonymous with Continuous Digital Code Squelch System (CDCSS). This manual will refer to CDCSS as Codes or DCS.
Channel Signaling Duplex	Tones, Codes, TGID, or NAC. The radio will use independent channel attributes for transmit and receive operation. This will allow the radio to transmit and receive on different frequencies.
DTMF Sidetone	DTMF audio that is fed into the operator's headset. This allows the operator to hear the DTMF signal being transmitted.
Focused Radio	Defined as the radio that shows all channel attributes on the home screen. This can be selected by pressing the radio select button.
Profile Hash	A unique alphanumeric string that is calculated based on the active configuration.
Key	A password that is unique to each MTP and allows for the enabling of extended feature sets.
Label	A user defined name that can be assigned to a specific Tone, Code, NAC or TGID. This name can be displayed instead of the predefined code.
Latch	A feature held in an on state.
List	A grouping of list members that have the same attributes. The different lists supported by the MTP are Tone, Code, NAC, TGID, and Zones.
MCODE	A tone set standard created by Motorola. This is frequently referred to as Private Line (PL) code.
Scanning	Automated procedure where a defined list of channels is monitored for incoming radio transmissions.
Sidetone	Microphone audio that is fed into the operator's headphone. This provides the ability for the operator to hear themselves talk while transmitting.
Simplex	The MTP will only use a channel's receive channel attributes for any transmit operation. This will cause the MTP to transmit and receive on the same frequency.
TGID	Logically grouped users used to subdivide channel traffic within a radio system.
Tones	This term is synonymous with Continuous Tone Code Squelch System (CTCSS). This manual will refer to CTCSS as Tones.
WCODE	A CTCSS tone set that follows the Wolfsburg standard.
Zone	A list of channels with editable properties and permissions that are not associated with channel attributes.

Section 1.0 Description

1.1 Introduction

Information in this section consists of product description, design features, specifications, and regulatory statements for the MTP Mission Transceiver Panel Mount, herein subsequently referred to as the MTP. All derivative product information will be contained in the applicable manual supplement, which may be obtained from AEM as required.

Review all notes, warnings, and cautions.

1.2 Product Description

The MTP Mission Transceiver Panel Mount Radio is a VHF FM transceiver that is equipped with a main and guard radio. The programmable guard radio has full feature equivalence to the main radio. The MTP is capable of semi-duplex communication and features two operating modes: narrowband analog, wideband analog. The MTP transmit and receive frequency range is the 136 – 174 MHz VHF band with high (10W) or low (1W) transmit output power selectable from the front panel interface. Continuous Tone Code Squelch System (CTCSS) and Continuous Digital Coded Squelch System (CDCSS) encoding/decoding are selectable. The panel mount radio is controlled using its front panel mounted number pad, knobs, and switches. Radio channel information and functions are displayed on a NVIS high-resolution screen.

IMPORTANT: The following **features are disabled** by default.
Contact AEM to enable these features:

- Agile Edit (Allows for inflight channel, and zone edits).
- Wideband (25 kHz channel bandwidth) operation.



Figure 1: MTP

1.3 Features

The MTP is capable of half-duplex communication. The MTP is able to receive simultaneously on both the main and guard radio or transmit on one radio. The MTP is designed for high temperature operating environments allowing industry leading high power transmit durations.

The MTP is factory configured to have a main radio and a dedicated guard radio. Regardless of configuration, the main and guard radios will always receive independently.

The MTP supports the use of 5000 channels that can be assigned to 40 different zones. To accommodate changing mission requirements each channel and zone can be edited in flight using the Agile Edit feature without requiring a power cycle. Each zone can contain a mixture of wideband and narrowband analog channels with each channel having fully independent and customizable properties.

Channel Signaling lists can be configured to ensure the operator has quick access to commonly used signals. Lists are fully customizable and allow the operator to only navigate through the Channel Signaling items that are relevant to the mission. Lists do not limit the operator from accessing all available Channel Signaling items, they are only a quick selection method.

The comprehensive set of MTP permissions allows the administrator to restrict Agile Edit functionality of specific channel properties on a per zone basis. If it is undesirable to allow the operator to utilize Agile Edit, the feature can be disabled entirely.

Scanning can be used to monitor multiple channels at once. Two priority channels and 5 scanning algorithms are supported: List, Priority, List + Priority, Zone, Zone + Priority. The MTP pauses scanning when a transmission is received on a scanned channel and allows the operator the opportunity to respond.

Fleet operation can be quickly configured and maintained using the Front Panel USB-C DATA port and a USB-C thumb drive. The DATA port allows importing a different profile or exporting the current profile. Unique sequences of numbers and letters called hashes can be used by fleet managers to conveniently compare the profiles of multiple MTP's in the field. These are on-screen identifiers that uniquely represent parts of the current profile.

The MTP panel backlighting is hardware and firmware dimmable to match the brightness level of other equipment in the cockpit. The hardware dimming is achieved through a single input that can be firmware configured to accept a 0-5 V_{DC}, 0-14 V_{DC} or a 0-28 V_{DC} input range.

The MTP is easily integrated into tactical systems and is a plug-and-play replacement for existing and legacy radios. The MTP is intended for single user operation and features one MIC Key input which functions as a Push To Talk (PTT). Different headset configurations are supported though a 12 V_{DC} configurable microphone bias.

1.4 Specifications

All requirements and specifications relating to mechanical, electrical, or environmental performance can be found in the MTP138-000GN-618-0 Declaration of Design and Performance.

1.4.1 Technical Characteristics

Product Characteristic	
Physical Dimensions:	(L) 7.51" x (W) 4.96 x (H) 3.00" (length (L) behind panel includes BNC connector)
Operating Temperature Range:	-45°C to + 70°C
Ground Survival Temperature Range:	-55°C to +85°C
Cooling:	No passive or forced cooling required
Weight:	3.2 lbs. nom, 3.3 lbs. max
Number of Channels:	5000, simplex or duplex
Number of Zones:	40
Data Port:	USB-C (RS485 in/out, RS232 in)
Microphone Type:	Amplified Dynamic / Electret Single Ended
Tones:	All Standard CTCSS Tones
Codes:	All Standard CDCSS Codes
TGID:	0 – 65535
NAC:	0x000 – 0xFF
Discrete Input Characteristics	
Channel Select + Input:	Momentary Active Low (GND) - Internally pulled up to 5V
Channel Select - Input:	Momentary Active Low (GND) - Internally pulled up to 5V
Mic Key (PTT) Input:	Active Low (GND) - Internally pulled up to 5V, GND to activate
Electrical Characteristics	
System Power Input Voltage:	28.0 V _{DC} (18 V _{DC} min, 32.2 V _{DC} max)
System Power Input Current:	0.275 A _{DC} max (Idle) 0.55 A _{DC} max (In Receive Mode) 2.75 A _{DC} max (In Transmit Mode)
Panel Lighting Voltage (Selectable):	5.0 V _{DC} 14.0 V _{DC} 28.0 V _{DC}
Panel Lighting Current:	< 5mA
Mic Audio Input:	100 mV _{RMS} ± 10%
Mic Bias (No Load):	12 V _{DC}
Audio Load Characteristics	
Microphone:	150 Ω ± 20%
Receive Audio Output:	600 Ω

RF Characteristics

Frequency Range:	136.0000 to 173.9975 MHz
RF Impedance (In/Out):	50 Ω nominal
Modulation:	FM (Analog)
Rated System Deviation:	±2.5 kHz max (Narrowband) ±5.0 kHz max (Wideband)

Transmitter Characteristics

RF Output Power:	1W, 10W Selectable
Receive FM Hum and Noise:	≥ 40 dB (Wideband) ≥ 34 dB (Narrowband)
Audio Distortion:	2% Typical, ≤ 4% max
Frequency Stability:	≤ 1 ppm Typical, ≤ 2.5 ppm max
Transmit FM Hum and Noise:	52 dB (Wideband) Typical, ≥ 40 dB min 48 dB (Narrowband) Typical, ≥ 34 dB min

Receiver Characteristics

Analog Reference Sensitivity	≤ 0.45 μV @ 12 dB SINAD
------------------------------	-------------------------

1.4.2 Summary of DO-160G Environmental Test Conditions

Table 1 defines the applicable minimum standard environmental test conditions used to determine the performance of the MTP. See Appendix B: Environmental Qualification Form for more information.

Conditions	Section	Category
Temperature and Altitude	4.0	B2, D1
Temperature Variation	5.0	S2
Humidity	6.0	A
Operational Shock and Crash Safety	7.0	B
Vibration	8.0	S, U
Explosive Atmosphere	9.0	H
Fungus Resistance	13.0	F
Salt Fog	14.0	S
Magnetic Effect	15.0	A
Power Input	16.0	ZXX
Voltage Spike	17.0	A
Audio Frequency Conducted Susceptibility	18.0	Z
Induced Signal Susceptibility	19.0	ZCX
Radio Frequency Susceptibility	20.0	RR
Emission of Radio Frequency Energy	21.0	M
Lightning Induced Transient Susceptibility	21.0	XXJ3L3
Electrostatic Discharge	22.0	A
Fire, Flammability	24.0	X, 14 CFR Far 23.853 Compliance by Analysis

Table 1: Summary of DO-160G Environmental Testing

1.5 Product Approval/Certification

Declaration of Design and Performance to RTCA/DO-160G, TIA-603-E, TIA-102.CAAB-D, and FCC/ISED Certification Rule 47, Part 22 & Part 90.

FCC ID: ZC7-MTPB1GN

ISED certification number: IC: 9601A-MTPB1GN

HVIN: MTPB1GN

Models (PMNs): MTP136D-000GN, MTP138-000GN

FCC/ISED Emission Designators:

11K0F3E	Analog Voice	Analog FM	NB Voice
16K0F3E	Analog Voice	Analog FM	WB Voice
8K10F1E	P25 Phase 1	CF4M	Digital Voice
8K10F1D	P25 Phase 1	C4FM	Data/Control Channel
8K10F7W	P25 Phase 1	C4FM	Data/Control Channel

1.6 Product Limitations

Front Panel DATA Port is for maintenance activities only and is not intended for use during flight. Font Panel DATA Port door is to remain closed during flight.

1.7 Unit Nomenclature

The product part number is defined as follows:

M	T	P	1	3	8	-	0	0	0	G	N
1			2		3		4		5		6

Item	Name	Description
1	Product Family	MTP: Mission Transceiver Panel Mount
2	Start Frequency (in MHz)	138: 138 MHz
3	Feature Character	N/A: Analog only D: Digital capable
4	Derivative Identifier [000-999]	000: Base product
5	Feature Character	G: Guard receiver installed N/A: No guard
6	Feature Character	N: NVIS compliant lighting N/A: Non-NVIS lighting

Table 2: Unit Nomenclature

1.8 Key Enabled Features

To comply with the FCC CFR Part 90.203 and ISED RSS 119, the following features are disabled by default:

- Agile Edit (allows for inflight channel, and zone edits)
- Wideband Analog Bandwidth

It is the responsibility of the installer or operator to determine if they meet exceptions to get these features enabled.

To enable these features please contact AEM Technical Support at support@aem-corp.com with the serial number of the unit.

1.9 Regulatory Statements

1.9.1 ISED General Statements

1.9.1.1 ISED non-interference disclaimer

This device contains licensed transmitter(s)/receiver(s) that comply with Innovation, Science and Economic Development Canada's licensed RSS(s). Operation is subject to the following two conditions:

This device may not cause interference.

This device must accept any interference, including interference that may cause undesired operation of the device.

This device complies with the Canadian ICES-003 Class A specifications. CAN ICES-003(A) / NMB-003 (A).

L'émetteur/récepteur autorisée contenu dans le présent appareil est conforme aux CNR d'Innovation, Sciences et Développement économique Canada applicables aux appareils radio autorisée. L'exploitation est autorisée aux deux conditions suivantes:

1. L'appareil ne doit pas produire de brouillage.
2. L'appareil doit accepter tout brouillage radioélectrique subi, même si le brouillage est susceptible d'en compromettre le fonctionnement.

Cet appareil numérique de la Canadian ICES-003. Cet appareil numérique de la classe A est conforme à la norme NMB-003 du Canada.

1.9.2 ISED Additional Statement for Detachable Antenna

1.9.2.1 RSS-Gen Transmit Antenna Statement

This radio transmitter IC: 9601A-MTPB1GN has been approved by Innovation, Science and Economic Development Canada to operate with the antenna types listed below, with the maximum permissible gain indicated. Antenna types not included in this list that have a gain greater than the maximum gain indicated for any type listed are strictly prohibited for use with this device.

Le présent émetteur radio IC: 9601A-MTPB1GN a été approuvé par Innovation, Sciences et Développement économique Canada pour fonctionner avec les types d'antenne énumérés ci-dessous et ayant un gain admissible maximal. Les types d'antenne non inclus dans cette liste, et dont le gain est supérieur au gain maximal indiqué pour tout type figurant sur la liste, sont strictement interdits pour l'exploitation de l'émetteur.

Under Innovation, Science and Economic Development regulations, this radio transmitter may only operate using an antenna of a type and maximum (or lesser) gain approved for the transmitter by ISED. To reduce potential radio interference to other users, the antenna type and its gain should be so chosen that the equivalent isotropic radiated power (e.i.r.p.) is not more than that necessary for successful communication.

Conformément à la réglementation d'Innovation, Sciences et Développement économique Canada, le présent émetteur radio peut fonctionner avec une antenne

d'un type et d'un gain maximal (ou inférieur) approuvé pour l'émetteur par Innovation, Sciences et Développement économique Canada. Dans le but de réduire les risques de brouillage radioélectrique à l'intention des autres utilisateurs, il faut choisir le type d'antenne et son gain de sorte que la puissance isotrope rayonnée équivalente (p.i.r.e.) ne dépasse pas l'intensité nécessaire à l'établissement d'une communication satisfaisante.

Approved Antenna Types:

Characteristic	Comant CI-177-1	Comant CI-177-13	RAMI AV-14
Maximum gain:	3 dBi	3 dBi	3 dBi
Antenna type:	Whip	Whip	Wire
Radiation pattern:	Omni-Directional	Omni-Directional	Omni-Directional
Impedance:	50 Ohm	50 Ohm	50 Ohm
Connector type:	BNC-Female	BNC-Female	BNC-Female

Table 3: Approved Antennas

Note: Alternate Antennas with an equal or lesser gain may be substituted.

1.9.3 FCC Statements for Class A Digital Device

1.9.3.1 FCC Compliance Statement

This equipment has been tested and found to comply with the limits for a Class A digital device, pursuant to part 15 of the FCC Rules. These limits are designed to provide reasonable protection against harmful interference when the equipment is operated in a commercial environment. This equipment generates, uses, and can radiate radio frequency energy and, if not installed and used in accordance with the instruction manual, may cause harmful interference to radio communications. Operation of this equipment in a residential area is likely to cause harmful interference in which case the user will be required to correct the interference at his own expense.

This device complies with Part 15 of the FCC Rules. Operation is subject to the following two conditions:

1. This device may not cause harmful interference, and
2. This device must accept any interference received, including interference that may cause undesired operation. Please note that changes or modifications not expressly approved by the party responsible for compliance could void the user's authority to operate the equipment.

Changes or modifications not expressly approved by the party responsible for compliance could void the user's authority to operate the equipment.

1.9.4 Radio Frequency Exposure Information

1.9.4.1 ISED/FCC RF Exposure Statement

This equipment complies with FCC and ISED RSS-102 radiation exposure limits set forth for an uncontrolled environment. This transmitter must not be co-located or operating in conjunction with any other antenna or transmitter. In order to avoid the possibility of exceeding the FCC and ISED RSS-10 radio frequency exposure limits, this equipment should be installed and operated with minimum distance of 45.3

inches (1.15 m) between the antenna and your body during normal operation. Users must follow the specific operating instructions for satisfying RF exposure compliance.

Cet équipement est conforme aux limites d'exposition aux rayonnements FCC et ISED CNR-102 établies pour un environnement non contrôlé. Cet émetteur ne doit pas être installé ou utilisé en conjonction avec une autre antenne ou un autre émetteur. Afin d'éviter la possibilité de dépasser les limites d'exposition aux radiofréquences FCC et ISED, cet équipement doit être installé et utilisé avec une distance minimale de 45.3 inches (1.15 m) entre l'antenne et votre corps pendant le fonctionnement normal. Les utilisateurs doivent suivre les instructions spécifiques d'utilisation pour respecter la conformité à l'exposition aux RF.

Enclosures with metal parts may change the RF performance of the device, including its compliance with RF exposure guidelines, in a manner that not been tested or certified.

Les étuis dotes de pièces métalliques peuvent modifier les performances des radiofréquences de l'appareil, y compris sa conformité aux directives d'exposition aux radiofréquences, d'une façon qui n'a pas été testée ou certifiée.

1.9.4.2 Controlling Your Exposure to RF Energy

RF is a form of electromagnetic energy (as is sunlight), and there are recommended levels of maximum RF exposure. To control your exposure to RF and comply with the maximum exposure limits for occupational/controlled environments, follow these guidelines:

1. Do not talk (transmit) on the radio more than the rated transmit duty cycle. This is important because the radio radiates more energy when it is transmitting than when it is receiving.
2. While you are transmitting (talking or sending data) on the radio, you must ensure that there is always a distance of 45.3 inches (1.15 m) between people and the antenna. This is the minimum safe distance.
3. Use the radio only with approved antennas and attachments, and make only authorized modifications to the antenna otherwise you could damage the radio and violate FCC regulations.

For more information on what RF energy is and how to control your exposure to it, visit the FCC website at www.fcc.gov/oet/rfsafety/rf-faqs.html.

1.9.5 Health Canada Warning Statement

The installer of this radio equipment must ensure that the antenna is located or pointed such that it does not emit an RF field in excess of Health Canada limits for the general population; consult Safety Code 6, obtainable from the Health Canada's website <http://www.hc-sc.gc.ca>.

1.9.5.1 Compliance with RF Energy Exposure Standards

This two-way radio complies with these RF energy exposure standards and guidelines:

1. United States Federal Communications Commission, Code of Federal Regulations; 47 CFR § 1.1307, 1.1310, and 2.1091.
2. American National Standards Institute (ANSI) / Institute of Electrical and Electronic Engineers (IEEE) C95.1-1992.
3. Institute of Electrical and Electronic Engineers (IEEE) C95.1-1999 Edition.
4. European Directive 2004/40/EC on minimum health and safety requirements regarding the exposure of workers to the risks arising from physical agents (electromagnetic fields).

This radio complies with the IEEE and ICNIRP exposure limits for occupational/controlled RF exposure environments at operating duty factors of up to 50% talk to 50% listen.

1.9.5.2 Conformité Aux Normes D'exposition à L'énergie RF

Cette radio émetteur-récepteur se conforme aux normes et aux règlements d'exposition à l'énergie RF:

1. La Commission fédérale de la communication des Etats-Unis, Code de règlements fédéraux (CFR) Titre 47 Sections 1.1307, 1.1310 et 2.1091 (radios mobiles) ou 2.1093 (radios portatives).
2. American National Standards Institute (ANSI) / Institute of Electrical and Electronic Engineers (IEEE) C95. 1-1992.12 For your safety
3. Institute of Electrical and Electronic Engineers (IEEE) C95.1-1999 Edition.
4. La directive européenne 2004/40/EC concernant les prescriptions minimales de sécurité et de santé relatives à l'exposition des travailleurs aux risques dus aux agents physiques (champs électromagnétiques).

Cette radio se conforme aux limites d'exposition de l'IEEE (FCC) et ICNIRP pour les environnements d'exposition au rayonnement RF professionnel et contrôlé aux cycles de marche de 50% en mode transmission et 50% en mode réception.

1.9.6 FCC Narrowbanding Regulations

The following information applies to all radios, not just to those sold in countries where FCC regulations apply.

From 1 January 2013 it is an FCC requirement that land mobile radio systems must not operate channels with a bandwidth greater than 12.5kHz in the 150–174MHz frequency band. From this date all radios will be supplied with firmware that requires a firmware feature license to operate a wide bandwidth channel in this frequency band.

The 25kHz unrestricted wideband feature license is available to any customer who is not subject to the relevant FCC regulations, or who has an FCC waiver.

End of Section 1.0 Description

Section 2.0 Installation

2.1 Introduction

Information in this section consists of unpacking and inspection procedures, installation procedures, pre and post-installation checks, configuration procedures, and installation drawings.

This section assumes operational familiarity with the MTP. Please refer to MTP138-000GN-813-0 Operators Guide for quick operating instructions.

2.2 Unpacking and Inspection

Unpack the equipment carefully. Inspect the unit visually for damage due to shipping and report all such claims immediately to the carrier involved. Note that each unit should have the following:

1. MTP
2. Acceptance Test Report
3. Certificate of Conformity

Verify that all items are present before proceeding and report any shortage immediately to your supplier.

2.3 Warranty

Please refer to the standard product warranty conditions available on our website, www.aem-corp.com.

2.4 Installation Kit

The MTP is designed to be Dzus mounted. Installation using the MTP138-IKC installation kit is required.

If performing a conversion from a pre-existing 25 pin installation contact AEM Technical Support at support@aem-corp.com.

Note: The MTP138-IKC installation kit is not included in the MTP package contents.

The MTP138-IKC (crimp) installation kit consists of the following:

Qty	Description	Manufacturer	Mfr Part #	AEM Part #
1	D-Sub, Female Socket, 15 Crimp Housing (Pins Included)	Amphenol	M24308/2-2F	120-21-008
1	Field Serviceable BNC Coax Connector	Amphenol	031-202	120-51-001
1	D-Sub Backshell, Size 2 (15 position) w/Jackscrews (Cable Clamp Included)	Amphenol	D15000GE0	120-28-013

Table 4: Installation Kit Content

2.5 Front Panel



Figure 2: MTP Front Panel

Item	Name	Description
1	Main Volume Knob (MAIN VOL)	Adjusts the volume of the main radio. Detent turns the MTP OFF.
2	Monitor (MON)	Bypasses Squelch Threshold and Channel Signaling allowing all transmissions to be heard.
3	Channel Recall (RCL)	Returns to the previous channel.
4	Radio Select (MAIN GUARD)	Changes the Focused Radio.
5	Transmit Power (HI LO)	Changes transmit power.
6	Guard Volume Knob (GUARD VOL)	Adjusts the volume of the guard radio.
7	Rotary Selector (PUSH ENTER)	Changes channel, navigates, and modifies options.
8	Keypad and MENU	Shows/hides the MENU. Changes channel, navigates, and modifies options.
9	Data Port (DATA)	USB Type-C port used for Profile Import/Export, Error Log Export, and Firmware Updates.

Table 5: Front Panel Controls

2.6 Warnings

WARNING

High volume settings can cause hearing damage. Set the headset volume control to the minimum volume setting prior to conducting tests, and slowly increase the headset volume to a comfortable listening level.

2.7 Antennas

WARNING

To limit exposure to radio frequency fields that exceed exposure limits for people occupying the aircraft, install the antenna such that it is mounted EITHER on a ground plane that is between the antenna and the occupants of the aircraft, OR further than 45.3 inches (1.15 m) from the occupants of the aircraft.

The maximum allowable antenna gain is 3 dBi, please see Table 3: Approved Antennas in section 1.9.2.1 for more information.

Proper antenna installation is vital to ensure reliable operation of the MTP and the aircraft. For best results the following should be taken into consideration where applicable:

1. The aircraft manufacturer installation instructions are followed.
2. The antennas are as widely separated as practically possible and clear of large aircraft obstructions.
3. The antenna is mounted a minimum of 3 ft (0.9 m) or more from any navigation receiver antennas.
4. The antenna is mounted a minimum of 4 ft (1.2 m) or more from communication and ELT antennas.
5. The antenna is not mounted at distances from the communication, navigation or ELT antennas that are $\frac{1}{4}$, $\frac{1}{2}$ or whole number multiples of the navigation or communications system wavelengths.
6. Antennas of like frequencies are not in proximity.
7. As much as practically possible, the antenna is not mounted near areas where contaminants such as fuel, dirt, oil, or water are likely to be present.
8. Best in-flight performance can be expected when the antenna is bottom mounted. Poor performance during ground testing may be observed for bottom mounted antennas due to signal reflection. Follow the antenna manufacturing installation recommendations.

Reference Figure 3, Figure 4, and Figure 5 below for antenna connection location and cable clearance considerations.

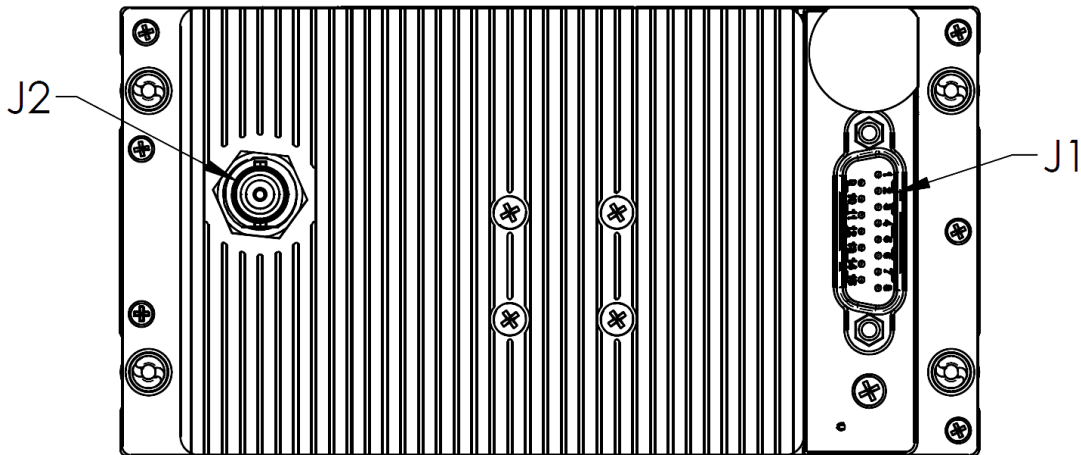

Figure 3: Connector J1 and Antenna J2 Locations

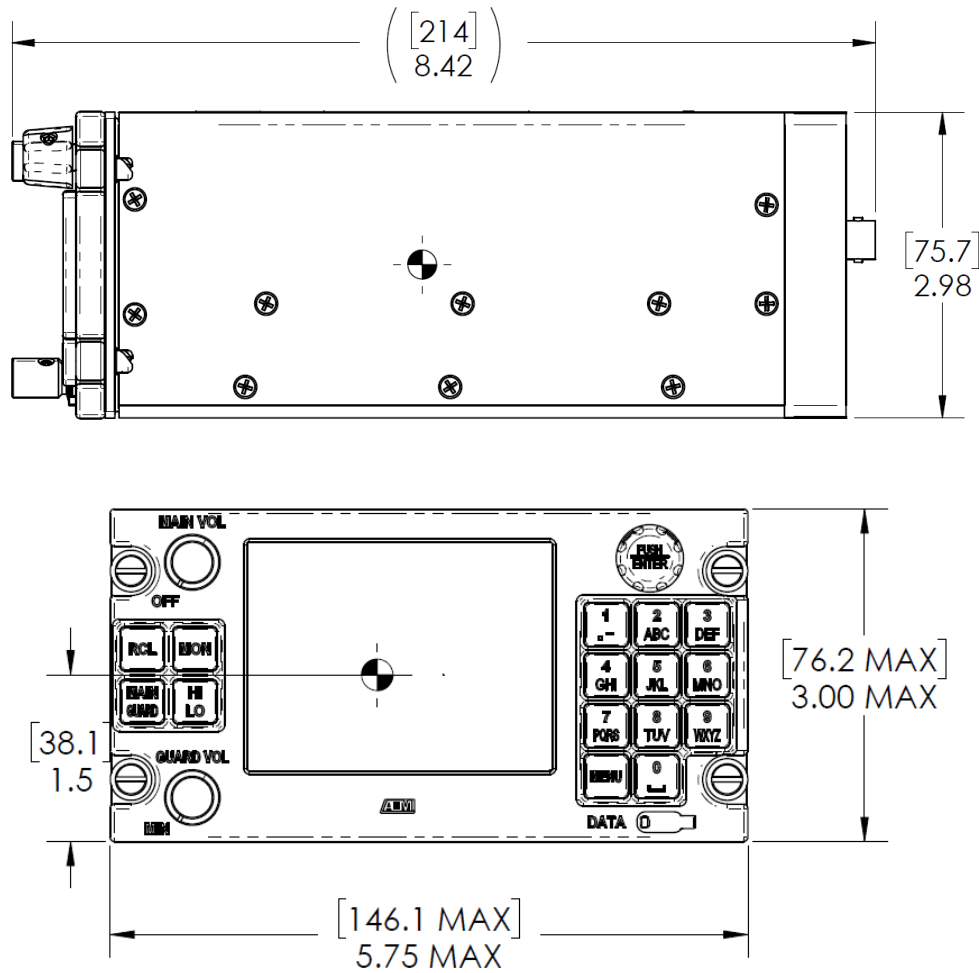

Figure 4: MTP Outer Dimensions (inches)

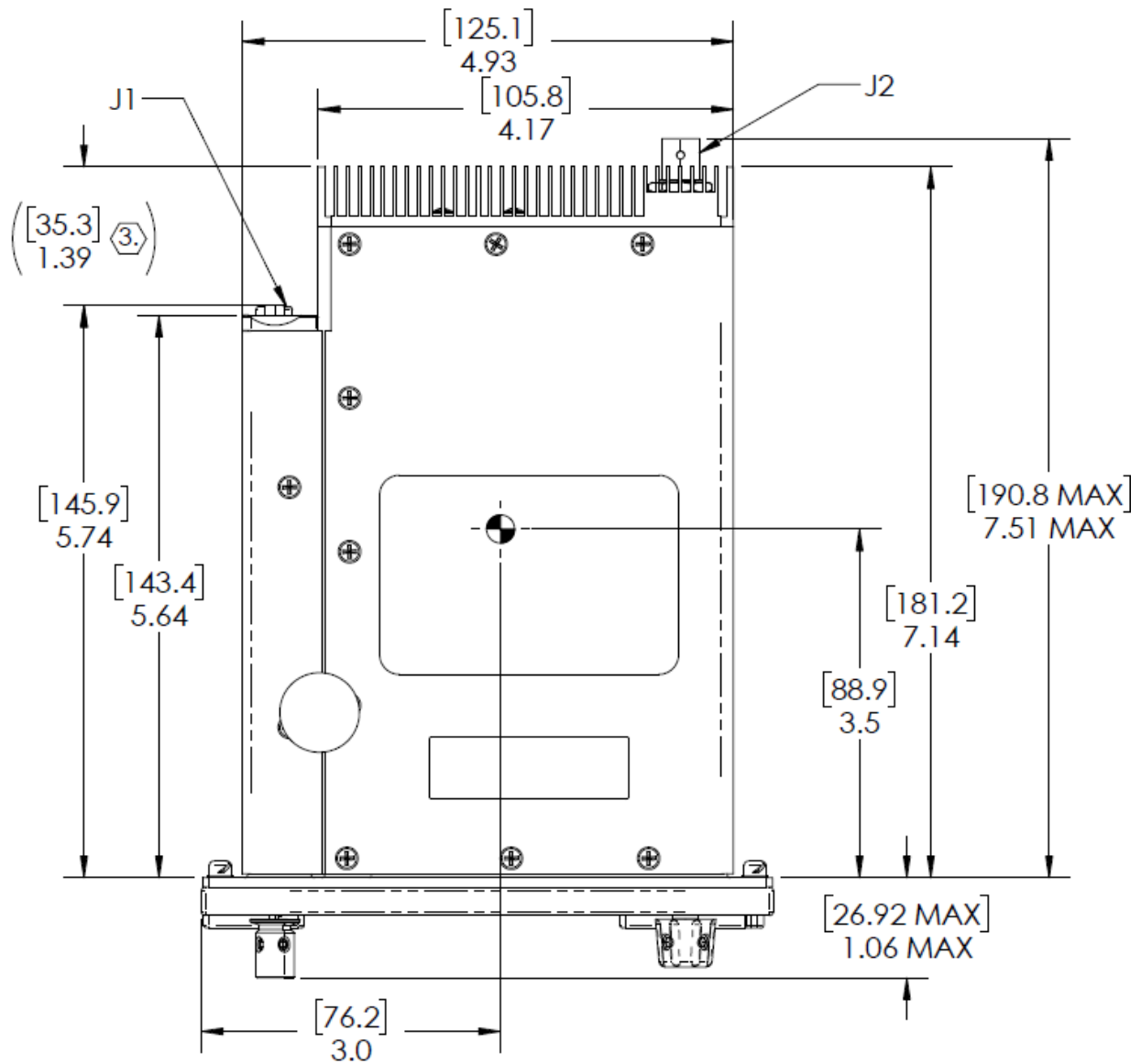

Figure 5: MTP Behind Panel Dimensions (inches)

2.8 System Interface Connector

CAUTION

Verify all airframe connections are checked against the Interconnect drawing.

Pin #	Pin Name	Pin Description
1	RX AUDIO HI	Headset Audio Out HI
2	RS485+	Serial Data Out
3	PANEL LIGHTING	5V, 14V, 28V Selectable
4	CHAN/SELECT +	Channel Select, Momentary Active Low
5	CHAN/SELECT -	Channel Select, Momentary Active Low
6	MIC AUDIO HI	Mic Input
7/14	+28 VDC POWER	Power
8/15	POWER GND	Ground
9	AUDIO LO	Mic In LO
10	RX AUDIO LO	Headset Audio Out LO
11	RS232 RX/RS485-	Serial Data In
12	N/C	Not Connected
13	MIC KEY IN	PTT – Active Low

Table 6: J1 System Interface Connector Pins

Note: Connector view is from rear of the MTP

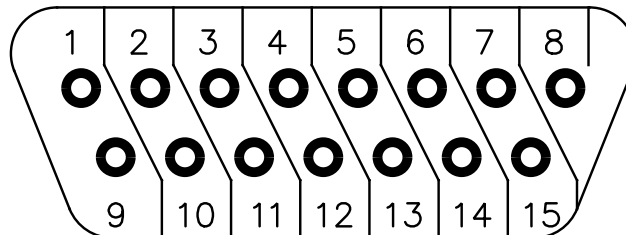

Figure 6: J1 System Interface Connector Map

2.9 Wiring Diagrams

CAUTION

Verify all airframe connections are checked against the Interconnect drawing.

Please reference Figure 7, Figure 8, and Figure 9 below for more detailed wiring information.

RETROFIT COMPATIBLE INSTALLATION

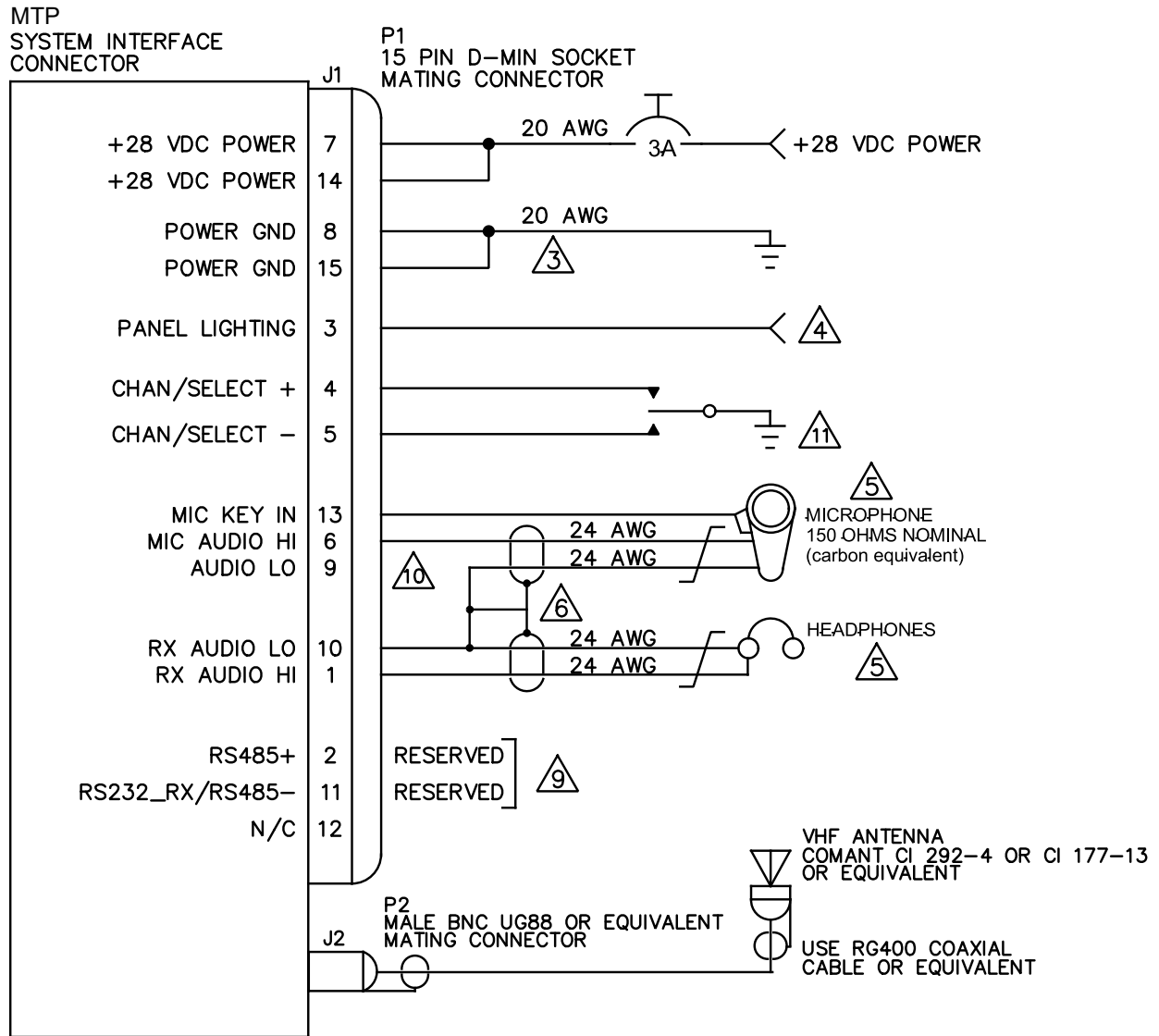

Figure 7: Interconnect Drawing for MTP

ALTERNATE INSTALLATION

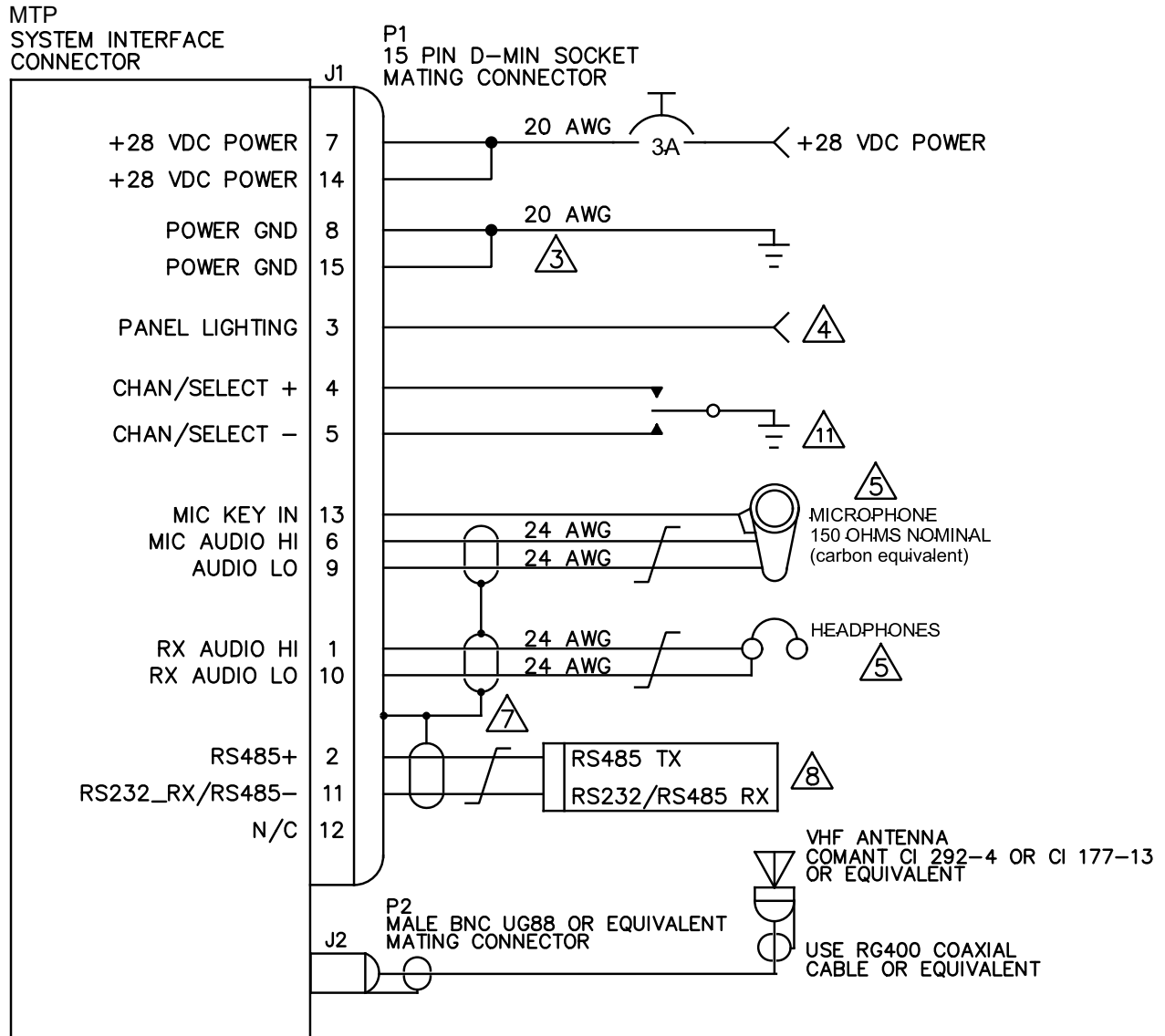

Figure 8: Alternate Interconnect Drawing for MTP

NOTES:

1. ALL WIRES SHALL BE 22 AWG UNLESS OTHERWISE SPECIFIED. ALL UNSHIELDED WIRE SHALL BE SELECTED IN ACCORDANCE WITH AC43.13-1B CHANGE 1, PARAGRAPHS 11-76 THROUGH 11-78. WIRE TYPES SHOULD BE TO MIL-W-22759 AS SPECIFIED IN AC43.13-1B CHANGE 1, PARAGRAPHS 11-85, 11-86 AND LISTED IN TABLE 11-11. ALL SHIELDED WIRE/CABLE SHOULD BE IN ACCORDANCE WITH MIL-C-27500.
2. CABLE LENGTH SHALL NOT EXCEED 17 FT. [5.18 M], UNLESS OTHERWISE SPECIFIED. COAXIAL CABLE MAY EXCEED THIS CABLE LENGTH TO ADDRESS AIRCRAFT INSTALLATION REQUIREMENTS.
3. PROVIDE SHORT RETURN TO AIRFRAME GROUND, CABLE LENGTH NOT TO EXCEED 3.3 FT. [1.0 M].
4. 5V, 14V OR 28V LIGHTS MAY BE WIRED WHEN APPLICABLE.
5. OR EQUIVALENT AUDIO MANAGEMENT UNIT CONNECTION. (PHONES AUDIO OR MICROPHONE AUDIO.)
6. SHIELDS ARE CONNECTED TO AUDIO LO (PINS-9,10) WITHIN THE METAL D-SUB CONNECTOR HOOD.
7. SHIELDS ARE CONNECTED TO THE D-SUB CONNECTOR. TERMINATE SHIELDS TO METAL CONNECTOR HOOD. CONNECT WITH CABLE LENGTH NOT TO EXCEED 4 IN. [0.1 M]
8. OPTIONAL RS485 REMOTE INTERFACE.
9. NO CONNECTION IN AIRCRAFT.
10. PIN 9 IS NOT CONNECTED.
11. OPTIONAL REMOTE CHANNELLING/SELECT SWITCH, MAY BE LOCATED ON CYCLIC CONTROL, ETC.

DEFINITIONS:

- N/C: NO CONNECTION. THE PIN IS NOT CONNECTED TO ANYTHING INTERNALLY, AND THEREFORE SHALL HAVE NO CONNECTION EXTERNALLY.
- RESERVED: MAY BE CONNECTED AND USED IN THE FUTURE. THE CIRCUITRY MAY BE PRESENT OR ADDED TO ACTIVATE THE FUNCTION. THE PIN MAY BE USED FOR TEST PURPOSES. THERE IS NO EXTERNAL CONNECTION.

Figure 9: Interconnect Drawing Notes

2.10 Additional Wiring Information

Ensure wiring and coaxial cable materials used meet or exceed the aircraft certification basis. For some aircraft this includes Appendix F flammability requirements or later amendments of the applicable AWM and/or FAR design standards.

Reference Figure 7, Figure 8, Figure 9 for specific wire gauges.

Maintain wire segregation and route wiring in accordance with the original aircraft manufacturers standard practices and/or AC43.13-1B Chapter 11 Sections 8 through 12.

2.11 Electrical Bonding

Electrical Bonding is achieved through the Dzus mounting points during installation of the product. Dzus mounting points shall be electrically bonded to the airframe ground.

The use of a milli-ohmmeter is recommended to verify bonding. Reference AC 43.13-1B Change 1, Section 15 for additional information.

2.12 Pre-Installation Checks

Do not connect the MTP to the wiring harness until the checks in Table 7 and Table 8 are completed.

Wiring Harness Connector Pin Continuity Check (No Power to Connector)	Continuity Expected	Continuity Observed (Yes/No)
Pins 7 to 14	Yes	
Pins 8 to 15	Yes	
Pins 7/14 to each of the other connector pins	No	
Pins 8/15 to Pins 1, 2, 3, 6, 11, 12	No	
Pin 1 to Pins 9, 10	No	
Pin 6 to Pins 9, 10	No	
Pin 4 to Pin 8/15: CHAN/SELECT + Switch Deactivated	No	
Pin 4 to Pin 8/15: CHAN/SELECT + Switch Activated	Yes	
Pin 5 to Pin 8/15: CHAN/SELECT - Switch Deactivated	No	
Pin 5 to Pin 8/15: CHAN/SELECT - Switch Activated	Yes	
Pin 13 to Pin 8/15: MIC KEY IN Switch Deactivated	No	
Pin 13 to Pin 8/15: MIC KEY IN Switch Activated	Yes	

Table 7: Pre-Installation Continuity Checks

Wiring Harness Connector Pin Voltage Check (Power to Connector)	Expected Value (V)	Observed Value (V)
Pins 7 and 14 Power	28 V _{DC}	
Pins 8 and 15 Ground	0 V _{DC} (GND)	
Pin 3: Panel Lighting Activated and set to Max	5/14/28 V _{DC}	
Pin 3: Panel Lighting Deactivated	0 V _{DC}	

Table 8: Pre-Installation Voltage Checks

2.13 Post-Installation Checks

With the MTP connected to the wiring harness power up the aircraft's systems and confirm normal operation of the MTP using Table 9: Post Installation Checks.

MTP Functionality Check	Pass Criteria	Pass/Fail
Boot up: Turn MAIN VOL knob clockwise past the detent position to power on the MTP.	AEM Splash Screen viewed before Home Screen loaded	
Button Test: <ol style="list-style-type: none"> 1. MENU > More > System > Test. 2. Scroll down until "Last Button" is in view. 3. MENU > Button Test. <ol style="list-style-type: none"> a. Turn the rotary selector clockwise and counterclockwise. b. Press Push/Enter. c. Press each front panel button. d. CHAN/SELECT + and CHAN/SELECT - input. e. Press MENU and select any option to exit button test. 	Each Button Viewed in "Last Button" when Pressed	
Screen Test: <ol style="list-style-type: none"> 1. MENU > More > System > Test. 2. MENU > Screen Test. 3. Turn the rotary selector to change the screen colour. 	Black, Red, Green, Blue, White	

Table 9: Post Installation Checks

Locate and record the MTP Firmware Versions:	
<ol style="list-style-type: none"> 1. MENU > More > System > Info. 2. Locate and record the "System SW Ver.", "Main SW Ver.", "Guard SW Ver." 	
System Software Ver:	
Main Radio Software Ver:	
Guard Radio Software Ver:	

Table 10: MTP Firmware Versions

2.14 Post Installation Adjustments

2.14.1 MTP Firmware Versions

Where applicable, software features in this section may differ based on firmware version. This manual details features for firmware version 1.02. Confirm the firmware version by performing the following steps on the MTP:

1. MENU > More > System > Info.
2. Scroll down to item 3.

This section assumes operational familiarity with the MTP.

2.14.1.1 Admin Permission Level

Post installation adjustments will require access to the Admin Permission Level. Permissions allow for customizable access to channels, zones, and options. The supported permissions and associated passwords are listed in Table 11.

Permission Level	Password
User (default)	Empty password
Admin	iac

Table 11: Permission Levels

Login to the Admin Permission Level:

1. MENU > More > System > Login.
2. Enter the Admin Password.
3. Push Enter.

2.14.1.2 Key Installation

To comply with the FCC CFR Part 90.203 and ISED RSS 119, some features in the MTP are disabled. If a Key Enabled Feature is required, a unique alpha-numeric key that is linked to the MTP's serial number is necessary.

To acquire the unique alpha-numeric key for the Key Enabled Feature please contact AEM Technical Support at support@aem-corp.com with the serial number of the MTP.

It is the responsibility of the installer or operator to determine if they meet exceptions to have these features enabled.

MTP S/N	Agile Edit	Wideband

Table 12: Agile Edit and Wideband Keys

To install a Key:

1. Login to the Admin Permission Level.
2. MENU > More > System > Keys.
3. MENU > Add.
4. Enter the Key.
5. Push|Enter.
6. Repeat Steps 3 through 5 for additional keys.

2.14.1.3 Radio Profile

All options and lists are stored in a JSON file (.json) called a Profile. The Radio Profile can be Imported or Exported using a correctly formatted USB drive. There are two methods to create an MTP Radio Profile:

Note: Multiple profiles may be saved onto a single USB drive.

Creation of a new profile:

1. Use the Radio Profile Editor found on the MTP product page at www.aem-corp.com
2. Enter profile information manually into the MTP.

Cloning an existing profile:

1. Export an existing Radio Profile from an MTP (Cloning) to a USB drive.

2.14.1.4 USB Drive Requirements

The front panel Data Port supports USB drives with the following features:

1. Formatted to FAT, FAT32, or exFAT.
2. Power consumption less than 4.5W.
3. USB-C or connected through a USB-C adapter.
4. Mechanical requirements are outlined in Figure 10.

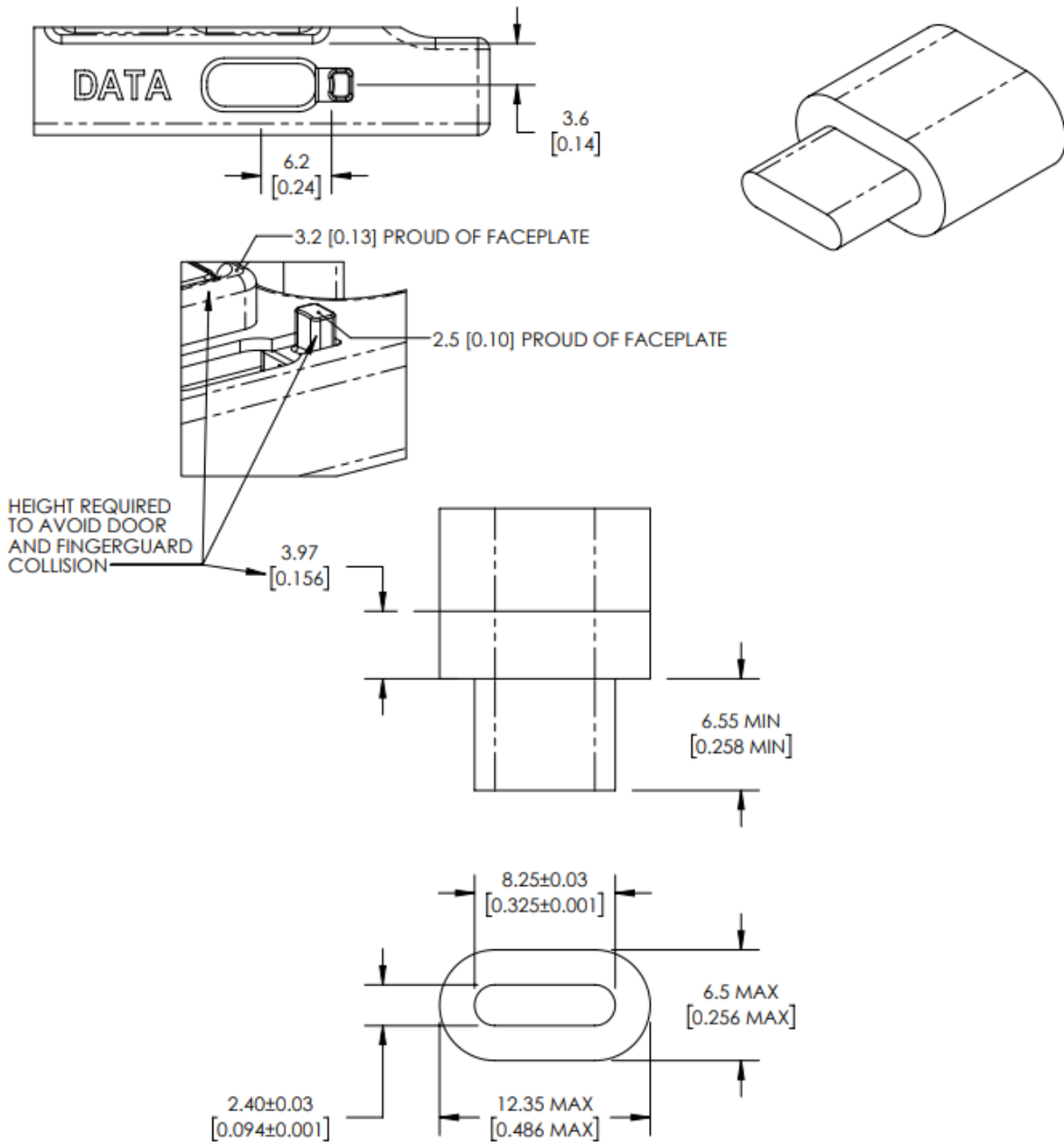

Figure 10: USB Drive Mechanical Requirements

2.14.1.5 Import Profile

Profiles can be imported from a USB drive connected to the MTP DATA port.

To Import a Profile:

1. Load a Profile onto the root directory of a USB drive.
2. MENU > More > Import.
3. Connect the USB drive to the DATA port.
4. Select the desired profile and press PUSH|ENTER.
5. MENU > Import.
6. Wait until a result is displayed. This may take a few minutes.

2.14.1.6 LCD Brightness Configuration

1. Confirm the MTP is in Day Mode. From the Home Screen: Menu > Bright > Menu > Day
2. From Admin Options, Menu > More > Options > Admin, scroll down to Item 17. Max Voltage. There are 3 settings available: 5V, 14V, and 28V. Set according to the airframe lighting bus.
3. Set Item 18. LCD Dimming to Enabled.
4. Turn ON the Airframe dimming bus.
5. From Admin Options scroll down to Item 21. Darkest and press Enter.
6. Adjust the Airframe dimmer to the desired position to achieve the minimum brightness, and press Menu > Read OR manually set the desired voltage level to achieve the minimum brightness. Press Enter.
7. From Admin Options scroll down to Item 22. Brightest and press Enter.
8. Set the Airframe dimmer to the desired position to achieve the maximum brightness and press Menu > Read > OR manually set the desired voltage level to achieve the maximum brightness. Press Enter.
9. From Admin Options scroll down to Item 23. Transition and press Enter.
10. Set the Airframe dimmer to the desired position to transition from Day to Night mode.
11. Press Menu > Read > Menu OR manually set the desired voltage level for the transition to occur. *See Table 15: MTP Admin Options* for the range of this setting.
12. Item 24. Day is set to **Below Transition** by default. Day mode will occur if the Airframe Dimmer voltage is below the selected Transition voltage. Alternately set to **Above Transition** as needed.
13. Item 25. Hysteresis sets the lead/lag between the Transition voltage and the actual voltage the backlighting transitions at. By default, it is set to 0.84V. Set as desired.
14. Press Menu > Save.
15. Select Menu > Bright > Menu > Auto to confirm operation. Repeat steps 1 – 13 to adjust as needed.

2.14.1.7 Audio Configuration

MTP audio settings may need to be adjusted to match the airframe audio management system. If required adjust the following settings:

2.14.1.7.1 Sidetone Volume and DTMF Sidetone Volume

1. From an operator licenced channel, transmit on the MTP and confirm clear sidetone is heard.
2. While continuing to transmit, press numbers 0 – 9 to confirm DTMF tones are heard and then stop transmitting.
3. To adjust sidetone volume press Menu > Radio and scroll down to Item 14. Sidetone Vol. and adjust as needed.
4. To adjust DTMF sidetone volume press Menu > Radio and scroll down to Item 15. DTMF Sidetone Vol. and adjust as needed.
5. Press Menu > Save to save all changes.
6. Repeat steps 1 and/or 2 to confirm changes.

2.14.1.7.2 Radio 1 (Main) and Radio 2 (Guard) Volume Range Adjustment

To configure a custom volume range set the MTP to receive frequency and press Menu > More > Options > User:

1. Adjust Radio 1 (Main) Min Volume:
 - a) Go to Menu Item 4 and press Enter.
 - Option 1: Set the Main Vol. knob to your desired minimum listening volume and press Menu > Read > Menu > Save.
 - Option 2: With the Main Vol. knob turned full counterclockwise, but not past the detent position, turn the Min Volume setting up until the desired minimum listening volume is achieved.
2. Adjust Radio 1 (Main) Max Volume:
 - a) Go to Menu Item 5 and press Enter.
 - Option 1: Set the Main Vol. knob to your desired maximum listening volume and press Menu > Read > Menu > Save.
 - Option 2: With the Main Vol. Knob turned fully clockwise, turn the Max Volume setting down until the desired maximum listening volume is achieved.
3. Repeat steps 1 and 2 for the Radio 2 (Guard) Min Volume (Menu item 9), and Radio 2 (Guard) Max Volume (Menu item 10).
4. Press Menu > Save to save all changes.

2.14.1.8 Admin and User Settings

Adjust all other settings and permission levels as required.

Reference Appendix A: MTP Installation Settings for a summary of available settings, ranges, and descriptions.

2.14.1.9 Profile Hashes

Settings, permissions, and channels in the MTP create unique identifiers called Profile Hashes. Profiles Hashes may be used to verify MTP Profiles across fleet installations or for troubleshooting purposes. Record the Profile Hashes into Table 13.

Locate the Profile Hashes by navigating to the MTP Info Screen and scrolling to items 7 to 10:

MENU > More > System > Info.

Profile Hashes	
User:	
Admin:	
Factory:	
Channels:	
ID Lists:	

Table 13: Profile Hashes

2.14.1.10 Export Profile

Profiles can be exported to a USB drive connected to the MTP DATA port.

The exported profile will contain all current settings accessible with the active permissions level.

To Export a Profile:

1. Connect a USB drive to the DATA port.
2. MENU > More > Export.
3. Using the Keypad enter the desired export filename.
4. MENU > Export.
5. Wait until a result is displayed. This may take a few minutes.

2.15 Airworthiness Approval Notes

Airworthiness approval of the MTP may require completion of a TCCA Major Modification Report per CAR STD (AWM) 571 Appendix L, FAA Form 337 or equivalent per local regulatory requirements. The sample wording for a description of the work is provided to assist the Installing Agency in preparing a Major Modification Report or equivalent when installing an Anodyne Electronics Manufacturing Corp MTP Mission Transceiver Panel Mount Radio. This sample may be modified appropriately for new installations. It is the installer's responsibility to determine the applicability of the method used. Installations performed outside Canada must follow the applicable aviation authority's regulations.

Sample Wording:

Installation of an Anodyne Electronics Manufacturing Corp MTP138-000GN Mission Transceiver Panel Mount Radio in [aircraft location].

Installed in accordance with this MTP138-000GN Installation Manual, Revision [], and AC 43.13-1B and AC 43.13-2B.

The MTP138-000GN interfaces with existing aircraft systems per the instructions in this Installation Manual.

This MTP138-000GN Installation Manual provides detailed installation instructions and wiring diagrams in Section 2.0 Installation.

Power is supplied to the MTP138-000GN through an []-Amp circuit breaker.

Aircraft equipment list, weights and balance amended. Compass compensation checked and found to conform to applicable regulations.

2.15.1 Instructions for Continued Airworthiness

Maintenance of the MTP138-000GN is 'on condition' only. Periodic maintenance of this product is not required. Instructions for Continued Airworthiness (ICA) for the Anodyne Electronics Manufacturing Corp MTP138 installation as part of a Type Certificate (TC) or Supplemental Type Certificate (STC) project shall comply with CAR STD (AWM) 523/527/525/529.1529 or FAR 23/25/27/29.1529 "Instructions for Continued Airworthiness".

2.16 Post Installation EMI Test

To perform the Post Installation EMI Test, follow the steps outlined in the Installation Approval Procedure MTP136D-000GN-634-0.

Note: MTP136D-000GN-634-0 is applicable to the MTP138-000GN.

2.17 Troubleshooting

Problem	Solution(s)
Radio Profile Import Failure	<ul style="list-style-type: none"> • Log into MTP as Admin. • Verify USB formatted to FAT, FAT32, or exFAT. • Verify USB drive functionality. • Confirm if wideband channels are present in radio profile. Are wideband channels required? If so, confirm wideband key is installed. • Check the Import Log located on the USB drive and contact AEM Technical Support.
Radio Fault Continuously Appears On Screen	<ul style="list-style-type: none"> • Contact AEM Technical Support. <p>Note: The MTP is designed to automatically recover from a radio fault.</p>
Poor Receive Audio Quality	<ul style="list-style-type: none"> • Check the electrical bonding of the MTP. • Check the electrical bonding of the antenna. • If RF signal strength is low, the Squelch Threshold can be adjusted to decrease the receive sensitivity. • Check the RF coax cable for corrosion, deformities, and proximity to other wires that may cause RF interference. • Check that Radio 1 (Main) and Radio 2 (Guard) radios are not on the same receive frequency. Both radios receiving on the same frequency will increase the output audio from the MTP and may cause distortion depending on the configuration with the audio management system.
No PTT	<ul style="list-style-type: none"> • If TX! Appears on screen PTT Timeout has been exceeded. Re-key PTT to continue transmitting and adjust PTT Timeout from Admin Options if desired. • Perform Section 2.12 Pre-Installation Checks. <p>Note: PTT Timeout prevents the MTP from continuously transmitting in the case of stuck PTT. It is not recommended to set PTT Timeout to “None”.</p>
Stuck PTT	<ul style="list-style-type: none"> • Turn the MAIN VOL knob on the MTP fully ccw past the detent position then turn cw to restart the radio and confirm the MTP continues transmitting automatically. • Perform Section 2.12 Pre-Installation Checks.
Channel Select +/- not functioning	<ul style="list-style-type: none"> • Perform Section 2.12 Pre-Installation Checks.

<p>Radio reboots while transmitting</p>	<ul style="list-style-type: none"> • Check if the MTP is rebooting in both LO power and HI power modes. • Disconnect the MTP J1 wiring harness connector and perform all essential continuity checks, voltage checks, and load tests. <p>Note: Rebooting during transmit only may indicate that not enough power is being supplied to the radio.</p>
<p>Radio continually reboots while in receive mode or idle.</p>	<ul style="list-style-type: none"> • Check that the MTP power input is stable and within operating voltage ranges. <p>Note: The MTP will automatically recover from power surges and under-voltage conditions.</p>
<p>Contact AEM Technical Support at support@aem-corp.com if none of the above resolves the problem.</p>	

Table 14: Installation Troubleshooting Guide

End of Section 2.0 Installation

Appendix A: Installation Options and Settings

Admin Options

Name	Description	Factory Default	Range
<u>All Radios</u>			
PTT Timeout	Disengages PTT after set time. Note: If set to "None" the MTP will disable the PTT Timeout.	90s	30s to 300s or None
Attenuation	Sets the receive sensitivity.	0dB	0dB, 6dB, 12dB, 20dB
P25 Unit ID	Not applicable to the MTP138	1	0 - 9999999
<u>Radio 1 (Main) Radio 2 (Guard)</u>			
Name	Radio name.	Main/Guard	Up to 15 digit, alpha-numeric
Zone Permission	Restrict/enable user access to other zones.	User	User, Admin
RESERVED			
<u>Startup</u>			
Zone	Set the zone the MTP will startup on. If set to Shutdown, the MTP will startup on the zone it was shutdown on.	Shutdown	1 of 40 possible zones, or Shutdown
Ch.	Set the channel the MTP will startup on. If set to Shutdown, the MTP will startup on the channel it was shutdown on.	Shutdown	1 of 5000 possible channels, or Shutdown
<u>Audio</u>			
Mic. Bias	Enable the 12Vdc microphone bias on the MIC AUDIO HI input.	Off	On/Off
Mic. Level	Adjust the transmit deviation.	77%	0% to 100%
DTMF Dialing	Enable DTMF tones.	On	On/Off
<u>Lighting</u>			
Max Voltage	Set the maximum aircraft panel dimming voltage.	28Vdc	5/14/28 Vdc
LCD Dimming	Display brightness will adjust with panel dimming in Night Mode.	Enable	Enable/Disable
<u>UI</u>			
Monitor Scope	Active: MON button operates on the Focused Radio. All: MON button operates on Radio 1 (Main) and Radio 2 (Guard) simultaneously.	Active	Active/All
Recall Scope	The RCL button will toggle between the last two channels on the selected radio. If set to Active, the RCL button will toggle between the last two channels on the Focused Radio.	Active	Active/Radio 1/Radio 2

LCD Dimming Range		(Lighting: Max Voltage 28V, 14V, 5V)	
Darkest	Set the voltage the LCD will be at the dimmest level.	<u>0.00V</u>	<u>28V</u> : 0V – 28V <u>14V</u> : 0V – 14V <u>5V</u> : 0V – 5V
Brightest	Set the voltage the LCD will be at the brightest level.	<u>28.00V</u>	<u>28V</u> : 0V – 28V <u>14V</u> : 0V – 14V <u>5V</u> : 0V – 5V
LCD Auto Mode			
Transition	Set the voltage the LCD will transition between Day/Night mode.	<u>5.60V</u> <u>2.80V</u> <u>1.00V</u>	<u>28V</u> : 1.40V – 26.60V <u>14V</u> : 0.70V – 13.30V <u>5V</u> : 0.25V – 4.75V
Day	Set Day mode to occur either above the transition voltage or below the transition voltage.	Below Transition	Below Transition Above Transition
Hysteresis	The voltage difference between the Day-to-Night and Night-to-Day transitions.	<u>0.28V</u> <u>0.14V</u> <u>0.05V</u>	<u>28V</u> : 0.28V – 1.40V <u>14V</u> : 0.14V – 0.70V <u>5V</u> : 0.05V – 0.25V

Table 15: MTP Admin Options

User Options

Name	Description	Factory Default	Range of Settings
<u>All Radios</u>			
Auto TX Power	On: Transmit power is set to the Active Channel transmit power on channel change or startup. Off: Transmit power persists across channel changes and power cycle.	Off	On/Off
Digital Monitor	This setting is not applicable to the MTP138	All	All/TGID
<u>Radio 1 (Main), Radio 2 (Guard)</u>			
Pri. Scan Rate	Sets the rate at which the MTP will scan Priority 1 and Priority 2 channels.	3000ms	1000ms to 5000ms (1 second to 5 seconds)
Min Volume	Sets the lowest volume level when the volume pot is turned fully counter-clockwise.	0%	0% to 100%
Max Volume	Sets the highest volume level when the volume pot is turned fully clockwise.	100%	0% to 100%
<u>Startup (Main), Radio 2 (Guard)</u>			
Zone	Set the zone the MTP will startup on. If set to Shutdown the MTP will startup on the zone it was shutdown on.	Shutdown	1 of 40 possible zones, and Shutdown
Ch.	Set the channel the MTP will startup on. If set to Shutdown the MTP will startup on the channel it was shutdown on.	Shutdown	1 of 5000 possible channels, Shutdown

<u>UI</u>			
Startup Radio	Sets the radio the MTP will startup on. If set to Shutdown, the MTP will startup on the radio it was shutdown on.	Shutdown	Shutdown/Radio 1 /Radio 2
Hold Time	Sets the button press hold time to enable/disable Menu Latch and Monitor Latch if these features are set to Hold.	500ms	500ms to 2000ms (0.5 seconds to 2 seconds)
Monitor Latch	Hold: MON must be held for the Hold Time period to latch the monitor. On: Monitor will latch as soon as MON is pressed. Off: Monitor will not latch.	Hold	Off/Hold/On
Menu Latch	Hold: MENU must be depressed for the Hold Time period to Latch the MTP MENU. On: MENU will latch as soon as MENU is pressed. Off: MENU will not latch.	Hold	Off/Hold/On
Auto Simplex	On: RX and TX on same frequency and signal, editing RX parameters will change TX parameters. Only RX parameters displayed (Simplex). Off: The RX and TX parameters displayed and edited independently (Duplex).	On	On/Off
Screen Names	Displays the name of each screen in the bottom left corner of the MTP.	On	On/Off
Go Home	Off: Only return to home screen from exiting current Menu. PTT: Activating PTT exits the current Menu and returns the display to the home screen. Radio Sel.: Pressing radio select (MAIN/GUARD) returns to home screen. Both: Pressing PTT or radio select returns the MTP to home screen.	Radio Sel.	Off/PTT/Radio Sel./Both
Primary Input	Radio: Turning the rotary selector will cycle between Radio 1(Main) and Radio 2 (Guard). Push Enter to change channel. Channel: Turning the rotary selector will cycle through the channels of the Focused Radio.	Channel	Radio/Channel
Scroll Down	Sets the scroll direction of the encoder.	CW	CCW/CW

Table 16: User Options

Radio

Name	Description	Factory Default	Range of Settings
<u>Radio 1 (Main) Radio 2 (Guard)</u>			
Zone	Selects the Active Zone.	N/A	1 of 40 possible zones
Ch.	Selects the Active Channel.	N/A	1 of 5000 possible channels
Sq. Threshold	Sets the receive Squelch Threshold.	Low	Low/Medium/High
Scan	Sets scan to on or off.	Off	On/Off
Scan Algo.	Sets scan algorithm to scan either Zone, List, Priority, List + Priority, Zone + Priority.	Zone	Priority, List, Zone, L+P, Z+P
TX Power	Selects transmit power.	Low	Low/High
<u>Audio</u>			
Sidetone	Turns transmit sidetone on or off.	On	On/Off
Sidetone Vol.	Sets transmit sidetone volume.	52%	0% to 100%
DTMF Sidetone Vol.	Sets the DTMF sidetone volume.	100%	0% to 100%
<u>UI</u>			
Labels	Turns on or off labels for lists viewable on the home screen.	Off	On/Off
Tone Format	Sets the format of Tones.	Frequency	Frequency/MCODE/WCODE
NAC Format	This setting is not applicable to the MTP138	Hex	Hex/Decimal
TGID Format	This setting is not applicable to the MTP138	Decimal	Hex/Decimal

Table 17: Radio Options

End of Appendix A

Appendix B: Environmental Qualification Forms

	ENVIRONMENTAL QUALIFICATION FORM
Description: <u>Mission Transceiver Panel Mount</u>	Document: <u>MTP138-000GN-521-0100</u>
Part #: <u>MTP138-000GN</u>	TSO #: <u>N/A</u>
Manufacturer's Specification and/or Other Applicable Specification: _____	
Manufacturer: <u>Anodyne Electronics Manufacturing Corp.</u>	
Address: <u>#100 – 966 Crowley Ave., Kelowna, BC, Canada. V1Y 0L1</u>	
DO-160 Rev: <u>G</u>	

Prepared By:  Calvin Doucette Designer 12-Feb-2026	Checked By:  Kris Erickson Designer 12-Feb-2026	Approved By:  Nikolas Andrews PRGMGR 12-Feb-2026
--	---	--

Change Record

Date	REV	ECO #	Change	Prepared By/ Checked By	
				CD	KE
12-Feb-2026	1.00	N/A	Initial Release.	CD	KE

	MTP138-000GN Environmental Qualification Form
---	---

Conditions	Section	Description of Conducted Tests
Temperature and Altitude	4.0	Equipment Tested to Category B2, D1
Ground Survival Low Temperature	4.5.1	-55°C
Short-Time Operating Low Temperature	4.5.1	-45°C
Operating Low Temperature	4.5.2	-45°C
Ground Survival High Temperature	4.5.3	+85°C
Short-Time Operating High Temperature	4.5.3	+70°C
Operating High Temperature	4.5.4	+70°C
In-Flight Loss of Cooling	4.5.5	Not Applicable (Reference Remarks: Item 3)
Altitude	4.6.1	50,000 ft. (15,240 m)
Temperature Variation	5.0	Equipment Tested to Category S2 >10°C/minute
Humidity	6.0	Equipment Tested to Category A 95%RH for 48 hours
Operational Shock and Crash Safety	7.0	Equipment Tested to Category B
Operational Shocks	7.2.2	6g for 11 ms in all axes
Crash Safety (Impulse)	7.3.2	20g for 11 ms in all axes
Crash Safety (Sustained)	7.3.3	20g for 3s in all axes
Vibration	8.0	Equipment Tested to Category S Curves B & M Equipment Tested to Category U Curve G (Reference Remarks: Item 4)
Explosive Atmosphere	9.0	Equipment Tested to Category H Surface Temperature ≤ 204°C
Waterproofness	10.0	Category X, no test performed
Fluids Susceptibility	11.0	Category X, no test performed
Sand and Dust	12.0	Category X, no test performed
Fungus	13.0	Category F, Qualified by Analysis
Salt Fog	14.0	Equipment Tested to Category S Subjected to corrosive atmosphere
Magnetic Effect	15.0	Equipment Tested to Category A Deflection of 1°: 0.3 m < D ≤ 1.0 m

AEM MTP138-000GN Environmental Qualification Form

Conditions	Section	Description of Conducted Tests
Power input	16.0	Equipment Tested to Category ZXX (Reference Remarks: Item 5)
Voltage (Average Value dc)	16.6.1.1	Nominal Operating Voltage: +28.0 Vdc Maximum Operating Voltage: +32.2 Vdc Minimum Operating Voltage: +18.0 Vdc Emergency Operating Voltage: Not Tested
Ripple Voltage (dc)	16.6.1.2	< 4 Vdc
Momentary Power Interruptions (dc)	16.6.1.3	As per DO-160G
Normal Surge Voltage (dc)	16.6.1.4	As per DO-160G
Engine Starting Under Voltage (dc)	16.6.1.5	As per DO-160G
Abnormal Momentary Undervoltage	16.6.2.3	+12.0 Vdc for 7 s
Abnormal Surge Voltage:	16.6.2.4	+80.0 Vdc for 100ms +48.0 Vdc for 1 s
Inrush Current Requirements (dc)	16.7.5	Category X, no test performed
DC Current Ripple tests (dc)	16.7.7	Category X, no test performed
Voltage Spike	17.0	Equipment Tested to Category A 600V _{pk} 10 μs Positive and negative spikes
Audio Frequency Susceptibility Ripple Voltage	18.0	Equipment Tested to Category Z 0.6 Vpp from 0.01 kHz to 0.20 kHz, to 1.6 Vpp from 0.2 to 1 kHz, to 4.0 Vpp from 1 to 15 kHz, to 0.6 Vpp at 15 kHz, to 0.004 Vpp at 148.5936 kHz
Induced Signal Susceptibility	19.0	Equipment Tested to Category ZCX
Magnetic Fields into Equipment	19.3.1	20 A _{rms} @ 400 Hz
Magnetic Fields into Interconnecting Cables	19.3.3	30 A m @ 400 Hz, reducing to 0.8 A-m @ 15 kHz
Electric Fields into Interconnecting Cables	19.3.4	1800 V-m from 380 Hz to 420 Hz
Spikes Induced into Interconnecting Cables	19.3.5	Positive and negative spikes as per DO-160G Figure 19-6
Radio Frequency Susceptibility	20.0	Equipment Tested to Category RR
Conducted RF Susceptibility	20.4	0.6 mA @ 10 kHz, increasing (log.), to 30 mA @ 500 kHz, to 30 mA @ 40 MHz, reducing (log.), to 3 mA @ 400 MHz
Radiated RF Susceptibility	20.5	20 V/m from 0.1 to 0.4 GHz (CW&SW) and 150 V/m from 0.4 GHz to 8.0 GHz (PM)

	MTP138-000GN Environmental Qualification Form
---	---

Conditions	Section	Description of Conducted Tests
Emission of Radio Frequency Energy	21.0	Equipment Tested to Category M
Conducted RF Emission	21.4	150 kHz to 152 MHz (Reference Remarks: Item 6)
Radiated RF Emission	21.5	100 MHz to 6 GHz
Lightning Induced Transient Susceptibility	22.0	Equipment Tested to Category XXJ3L3
Pin Injection	22.5.1	Category X, no test performed
Cable Bundle	22.5.2	Single Stroke, Level 3: Waveforms 1/3 Multiple Stroke, Level 3: Waveforms 1/3 Multiple Burst, Level 3: Waveform 3
Lightning Direct Effects	23.0	Category X, no test performed
Icing	24.0	Category X, no test performed
Electrostatic Discharge	25.0	Equipment Tested to Category A 15,000V Positive and Negative Spikes
Fire, Flammability	26.0	Category X, no test performed. Compliance to 14 CFR FAR 23.853 demonstrated by analysis. (Reference Remarks: Item 7)

<p>REMARKS</p> <ol style="list-style-type: none"> 1. Sections 20, 21, 22 were tested at CKC Laboratories Inc. 2. Sections 4 to 9, 14 to 19 and 25 were conducted at Anodyne Electronics Manufacturing Corp (AEM). 3. Section 4.5.5 Loss of Cooling not tested. No Passive or Forced Cooling required. 4. Section 8.8.2 Sine on Random test was performed on 3 units. 5. Section 16.0 Normal Maximum Operating Voltage conducted at Abnormal Maximum Voltage level to satisfy Normal and Abnormal maximum Operating Conditions. 6. Section 21.4 All power lines, interconnecting cables and RF cables were tested. 7. Not tested to Section 26.0 of DO-160G. The MTP was qualified by analysis to Federal Aviation Regulation (FAR) 25.853 – Horizontal Burn Rate less than 2.5in/min 8. All testing performed on MTP136D-000GN.
--

End of Environmental Qualification Form

Rev: 1.00	Feb 12, 2026	Page 4 of 4
-----------	--------------	-------------

ENG-FORM: 521-0101.DOTX

End of Appendix B